



PRODUCT OVERVIEW

SOLUTIONS. CLEVER. PRACTICAL.

 **di-soric**

WE ARE DI-SORIC

One of our most well-known developments was the innovative fork light barrier over 30 years ago – today we manufacture intelligent sensors based on all common functional principles, powerful image processing components, as well as high-quality LED machine and signal lighting for many sectors in industrial automation, such as assembly & handling, robotics, packaging, machine tools and measurement & testing.

And here we focus on the automotive, food & beverage, pharma & cosmetic and electronics industries. Our wide range of products is rounded off with our versatility for customer-specific solutions.

The foundation of our product solutions is constant work on development and comprehensive application knowledge. With high efficiency, flexibility, reliability and simple handling, our innovations enable the process reliability of applications – altogether: Solutions. Clever. Practical.



- **100% owner-managed**
- **Headquarters**
Urbach, Germany
- **Technology and production center**
Lüdenscheid, Germany
- **Representatives and branch offices**
in more than 40 countries
- **Certifications**
IQNet, ISO 9001:2015, ISO 14001:2015



WHEN WHAT MATTERS FOR YOUR ORDER IS HIGH AVAILABILITY ...

The di-soric webshop

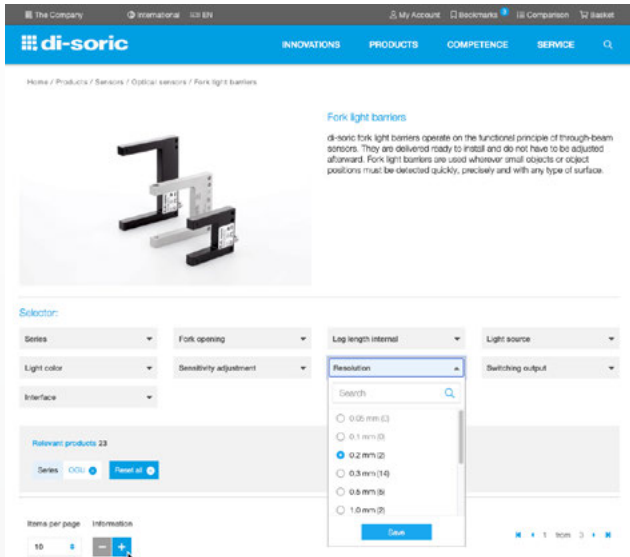

Product selectors: quickly find the right product by narrowing down characteristics

Get to the proper product quickly

- Convenient product selectors
- Fast, intelligent auto-suggest search
- Clear product series with background information
- Matching accessories and the ability to download technical documents and software directly at the article
- Comfortable product comparison



Up-to-date prices and availability in real time for every product

Easy ordering in the webshop

- Display of customer-specific pricing
- Display of current availability
- All of your orders at a glance with a reordering functionality
- Up-to-date product change information for your products
- Reminder list with export function, quick ordering, CSV import and direct placement of products in the shopping cart
- Payment by invoice or with credit card

Why do we offer you added value?

We are familiar with and understand the value-added processes applicable in your industry and, with our products and solutions, help you become faster, safer and more efficient.

Browse and learn more about our areas of competence and products.

PART FEEDING

TROUBLE-FREE AND SAFE OPERATION

As an upstream process for assembly, machining and packaging processes, reliable feeding of material is essential. di-soric offers various solutions for the correct storage, feed and provision of the components—each of them adequate for the individual requirement of the application.

Limited installation space, a wide variety of materials and sizes, high speeds and the increasing use of robots pose particular challenges to the control and monitoring of material feed. Compact designs and a high availability of the sensors, Vision sensors and signal lighting are required.

Optimized adjustment, maintenance and monitoring

In addition to the suitable product solution, easy integration into the system is also important for ensuring a reliable process. For this purpose, our products are equipped with industrial interfaces such as IO-Link, Ethernet TCP/IP, PROFINET, thereby supporting optimized adjustment, maintenance and monitoring of the entire system.

Trouble-free and safe operation

Also you can efficiently prevent machine downtimes caused by empty storage, material accumulation and incorrect orientation of components with di-soric sensors and solutions. It does not matter whether the application uses linear material feed, step feeders, circular or vibratory feeders, feeding in tubes or manual feed – our solutions ensure trouble-free and safe operation of your system.



Trouble-free and safe operation for applications in feeding of material:

Assembly and handling technology

- Storage of components and material
- Linear material feed
- Position monitoring of material feed
- Feeding material in the tube

Packaging technology

- Tubular bag and sealing machine
- Thickness measurement and profile

Robotics

- Sensors in robot-assisted processes

Image processing

- Vision sensors for more ambitious applications

Our sensors for material feeding;

Inductive ring sensors	Page 20
Inductive tube sensors	Page 22
Light barriers and diffuse sensors	Page 24
Fork light barriers	Page 28
Angled light barriers	Page 30
Frame light barriers	Page 32
Plastic fiber optic sensors	Page 34
Glass fiber optic sensors	Page 35
Ultrasonic barrier/sensors	Page 44
Vision sensors	Page 54

More info on
the topic here

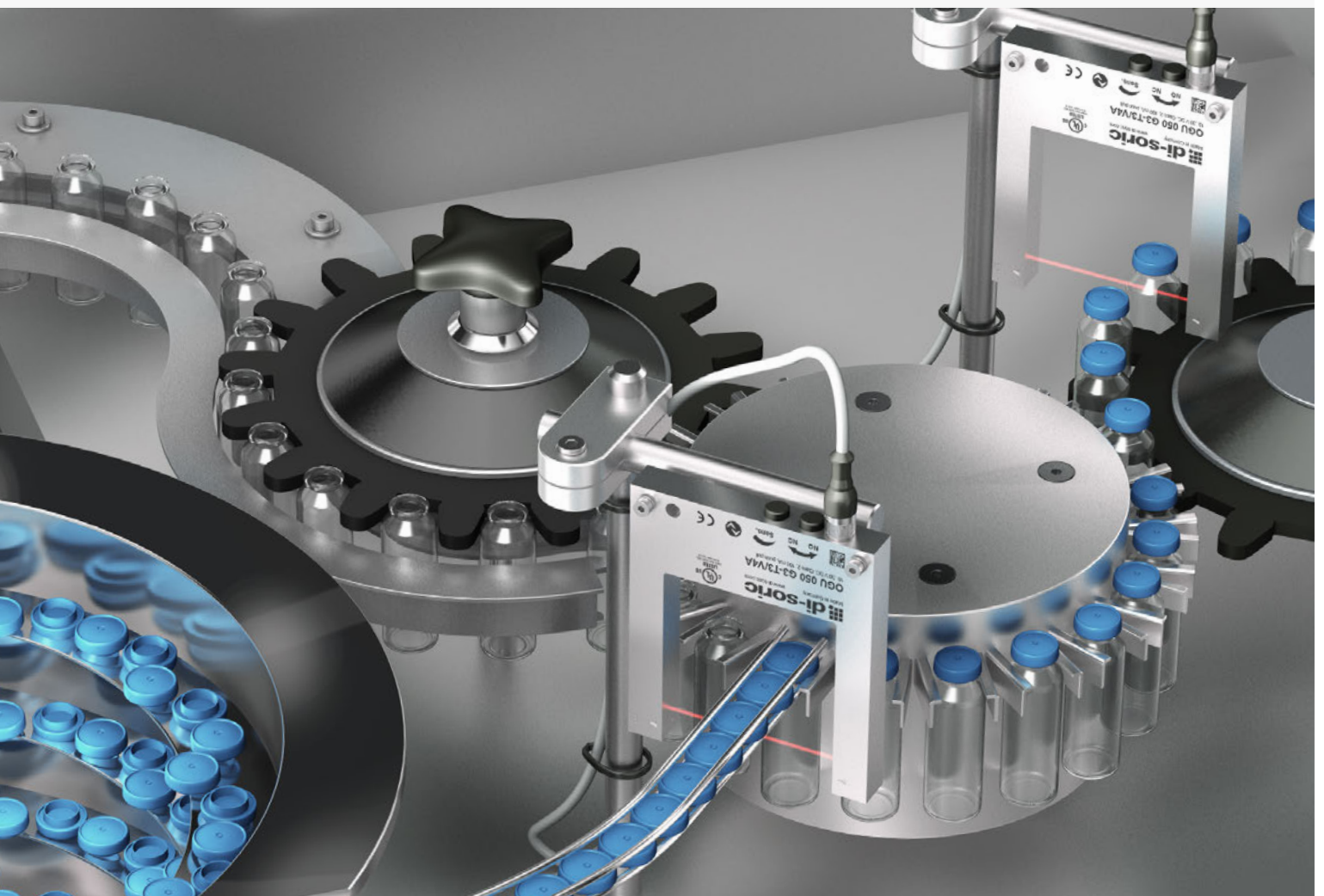



LABELING TECHNOLOGY WITH PRECISION AND MAXIMUM PRODUCTIVITY

di-soric offers various solutions for manufacture, dispensed feed and label checking – each of them adequate for the individual requirements of the application.

Diverse materials, various sizes, and high speeds present special challenges to control and monitoring in labeling technology. Compact designs and a high availability of the sensors and Vision sensors are required.

Our sensors for labeling technology:

Inductive proximity sensors	Page 18
Light barriers and diffuse sensors	Page 24
Optical distance sensors	Page 26
Plastic fiber optic sensors	Page 34
Optical label sensors	Page 38
Ultrasonic fork sensors	Page 46
Ultrasonic label sensors	Page 47
Capacitive label sensors	Page 49
Vision sensors	Page 54



More info on
the topic here

Applications in labeling technology:

Creating labels

- Roller diameter check
- Loop control system
- Web edge control
- Punching and detecting labels

Dispensing labels

- Identifying and positioning labels
- Detecting empty label coil
- Detecting end position at guide roller
- Triggering labeling

Checking labeling

- Position check for label fit
- Traceability of products
- Track and trace through 1D code capture
- Checking cover color

**Through simple adjustment,
our sensors make it easy to
achieve fast, process-reliable
and flexible production of
varying products and batch
sizes.**

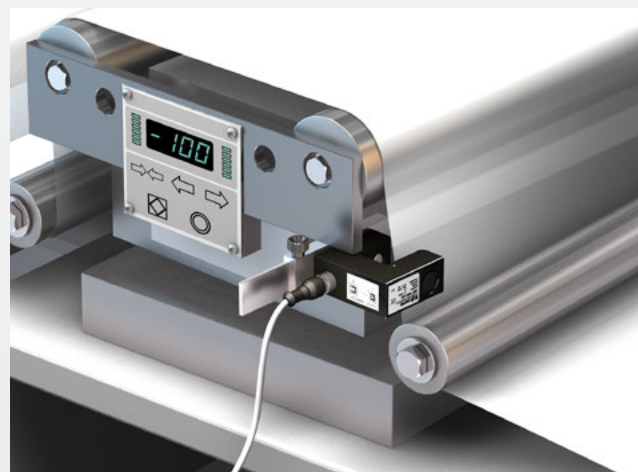
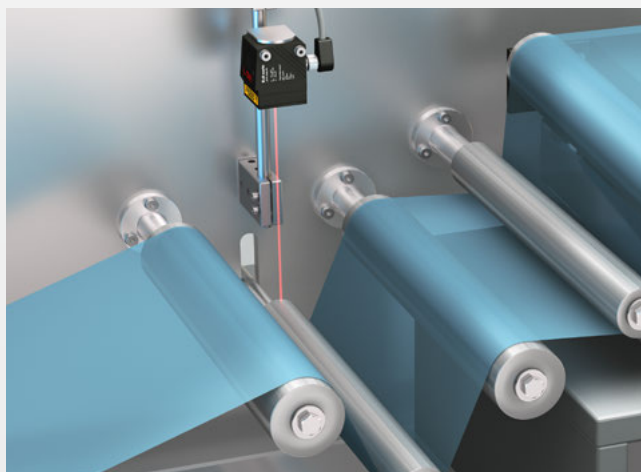

OPTIMAL DISTANCE MEASUREMENT IN AUTOMATION

In automation, there are the most diverse application scenarios: from measurements of fill level and object positioning to quality control. The diverse requirements, e.g. in relation to the object surface quality or the necessary precision, result from the specific application task. High resolutions, measurements on shiny or dark objects, high ranges and high ambient light safety – the selection of the right sensor plays a decisive role here.

We are thus able to offer you solutions for assembly & handling technology, packaging technology, robotics, lab automation, mobile work machines, machine tools, plastics and rubber.

Contact-free distance measurement for diverse applications in automation:

- Quality control
- Fill level
- Distance
- Positioning
- Diameter
- Thickness measurement and profile

To us, optimal distance measurement in automation means solving the most diverse applications with as few products as possible – contact-free!

Our sensors for distance measurement:

Optical distance sensors	Page 26
Ultrasonic barrier/sensors	Page 44

More info on
the topic here

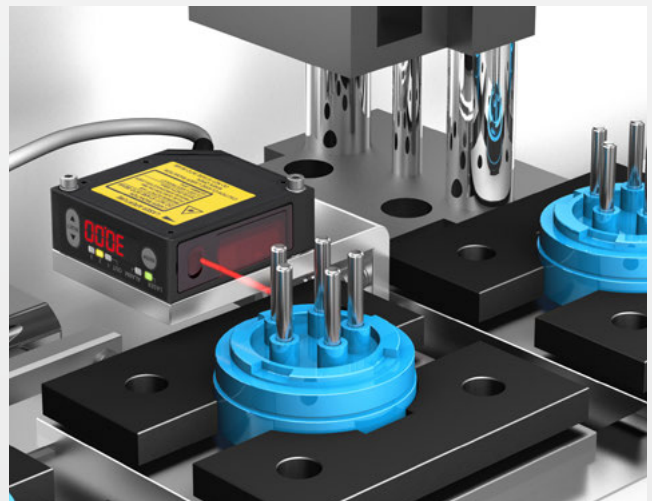
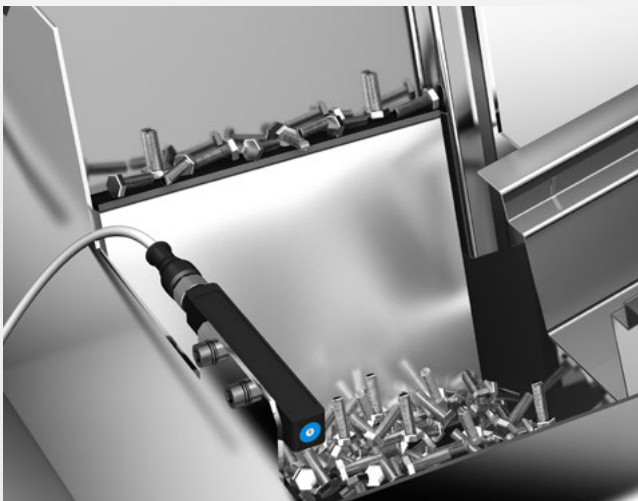

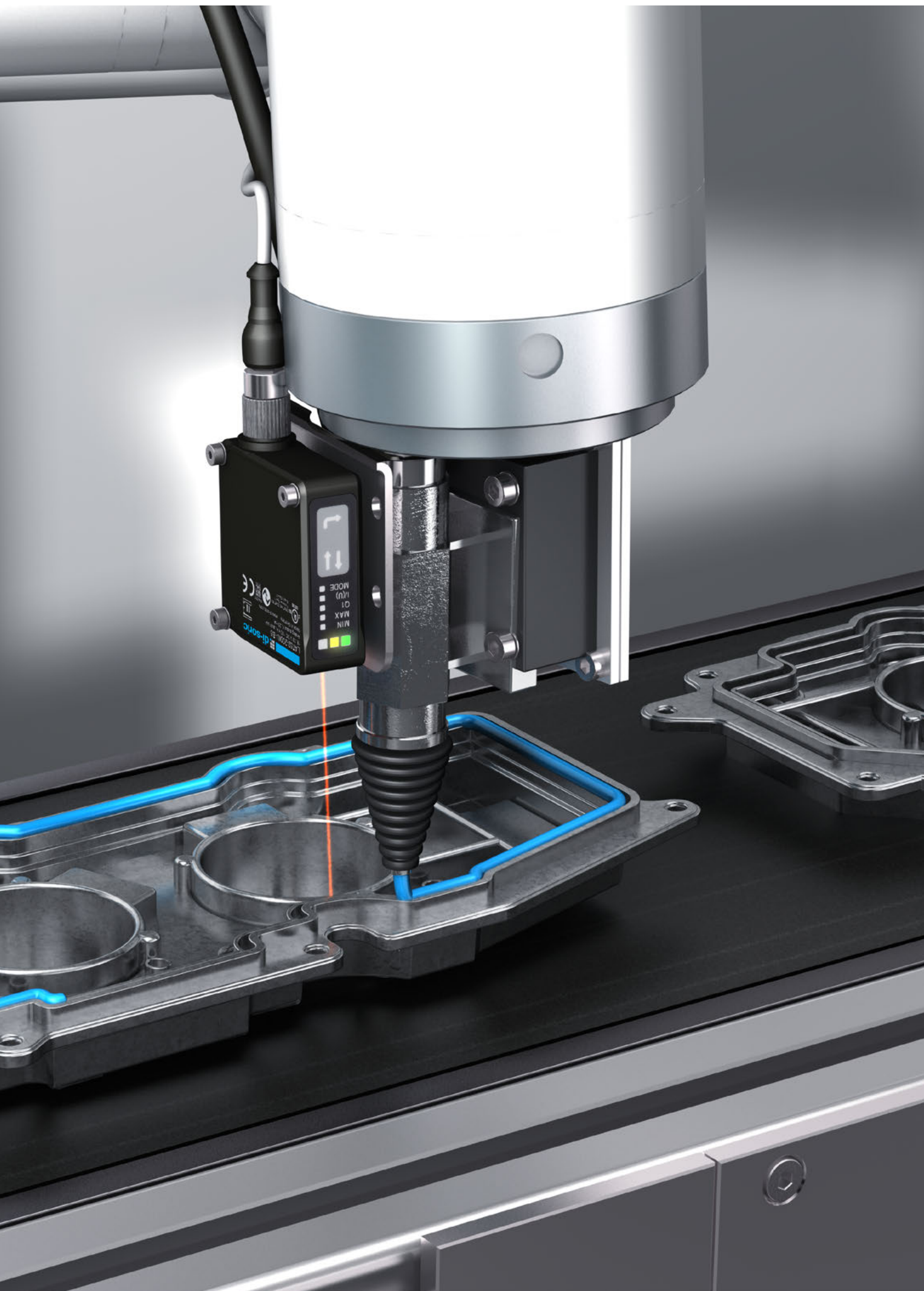

QUALITY INSPECTION CRUCIAL PROCESS STEP

Quality assurance is a crucial process step for all modern production systems. Availability and low pseudo-waste when checking qualitative requirements are highly significant here. Quality inspection systems are used for a wide variety of applications such as the production of single parts, the assembly of components as well as the inspection of finished products before packaging (end of line).

Queries about the presence of components, checking the correct mounting position or even checking whether or not parts are undamaged are all performed with high accuracy and availability guaranteed. di-soric offers a broad portfolio of high-performance sensors based on various technologies with innovative interfaces that offer additional value added.

Optimal quality testing to increase overall efficiency in the production process:

- Presence check
- Surface check
- Size accuracy check
- Type identification
- Type verification
- Position check

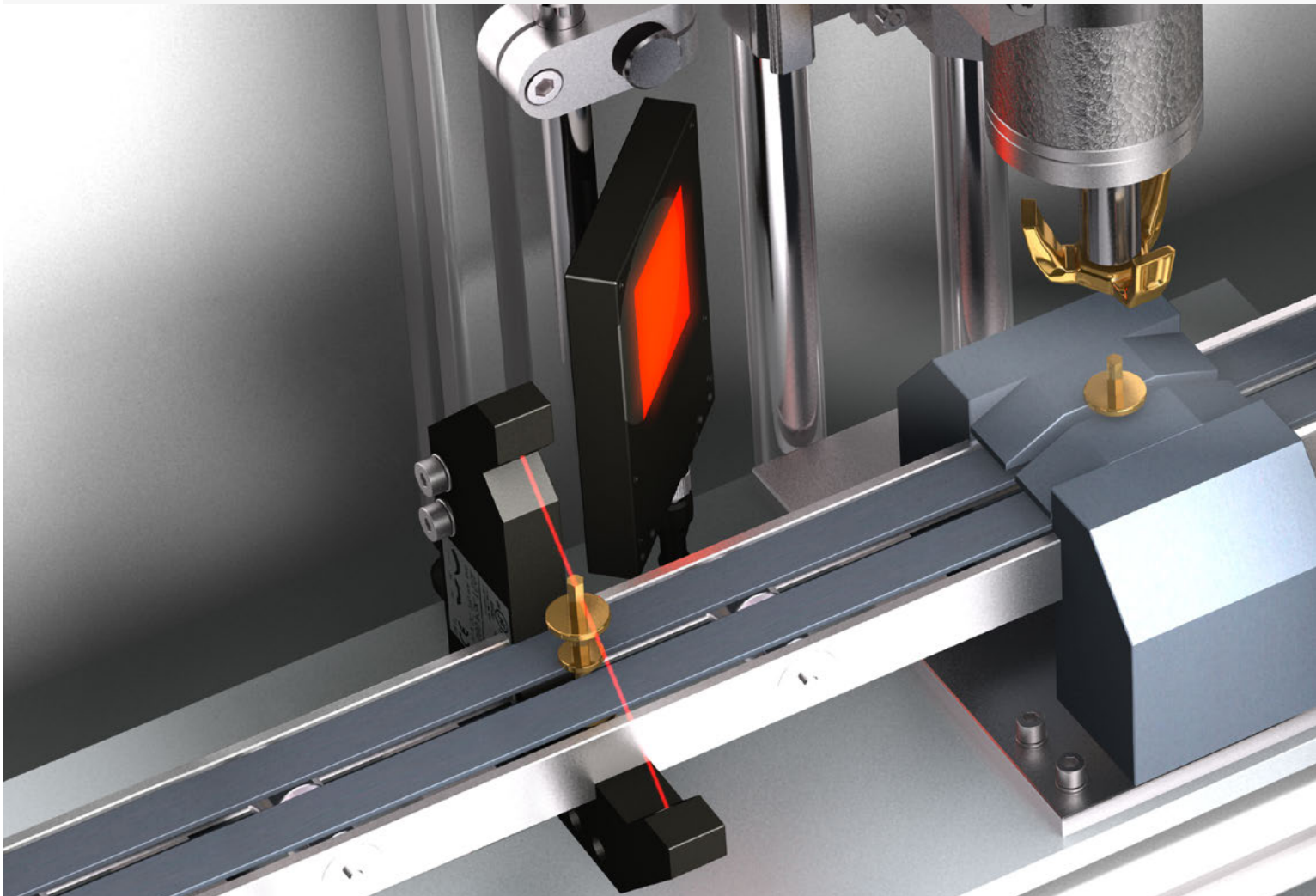

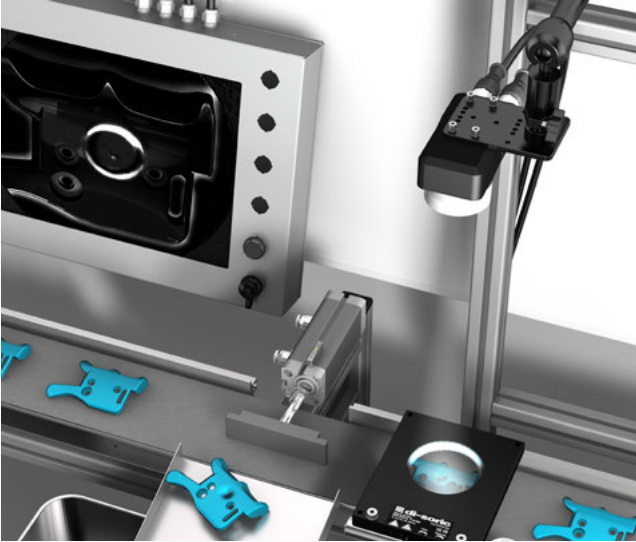

Our sensors for quality inspection:

Optical distance sensors	Page 26
Color sensors	Page 39
Profile sensors	Page 42
Handheld ID readers	Page 51
Fixed-mounted ID readers	Page 52
Vision sensors	Page 54
Lighting for industrial image processing	Page 58

More info on
the topic here



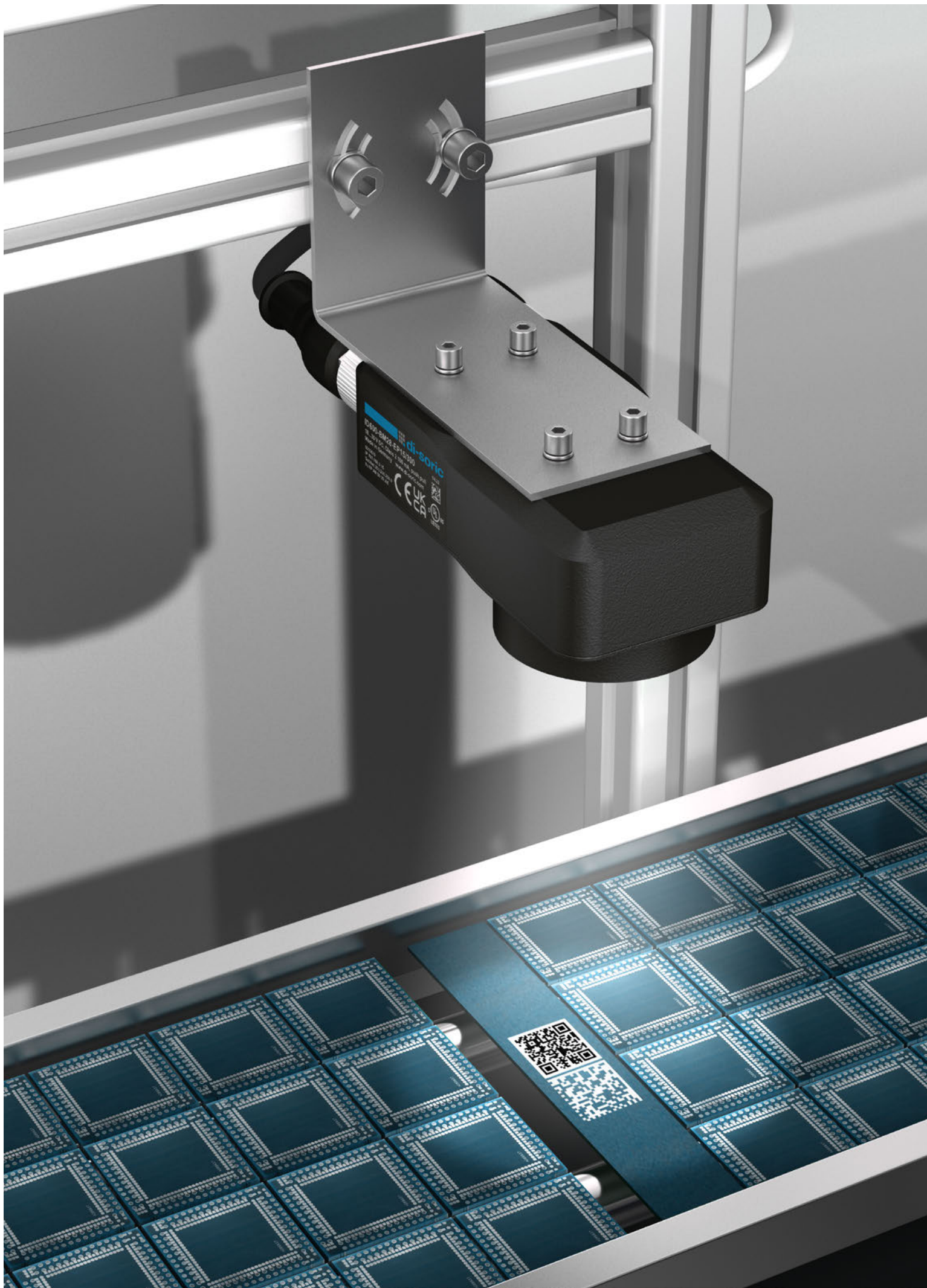

di-soric
D500-DMG-EP-15300
www.di-soric.com
CE UK

IDENTIFICATION

CODE READING IN FACTORY AUTOMATION

The essential characteristic of new production concepts is linking the information flow with the material flow. This enables the identification of the conveyor units at any time and at any location, ensuring versatile control at each production step.

A prerequisite is the reliable recognition of all common 1D and 2D codes by identification systems, such as our high-performance fixed-mounted and handheld ID readers and Vision sensors.

The advantages of camera-based code capture

Camera-based code readers – unlike laser scanners – use an area sensor to capture images of 1D and 2D codes. As a result, they are capable of detecting not only bar codes, but also data matrix, QR, maxi, miniature or even directly marked codes. Even dirty, damaged or incomplete 1D and 2D codes can still be read with a high probability of success. In addition to the data from the captured codes, the ID readers can transmit live images for documentation and subsequent analysis.

Multi-talented identification

The variety of objects, materials, code types, and ambient conditions that code readers have to cope with is increasing. This makes the use of versatile code readers all the more important and sustainable.

Our flexible code readers detect:

- 1D or barcodes
- 2D or stacked barcodes
- Data Matrix Code – DPM
- Hard-to-read codes
- Hard-to-identify direct markings
- Codes even on reflective and mirrored surfaces
- Colored codes, even on colored backgrounds
- Several codes simultaneously

Our products for identification:

Handheld ID readers	Page 51
Fixed-mounted ID readers	Page 52
Vision sensors	Page 54

More info on
the topic here



LIGHTING SOLUTIONS FOR INDUSTRY

The optimal illumination of machinery and systems in industry is an important factor for high productivity, since downtime during disruptions can be reduced through good visual conditions and unambiguous signaling. Good lighting conditions have a positive effect on dealing with visual tasks, work performance and work quality and ensure more safety in the workplace.

The requirements of industrial lighting are so diverse that there is no general, perfect solution for individual lighting that suits all industrial workplaces, machines or systems. The lighting series by di-soric are optimized for the specific requirements of various areas of deployment – from placement machines in clean rooms to processing centers in which robustness and insensitivity against, for instance colliding hot swarf or cooling liquid, play a decisive role.

Our lighting and lights are energy-efficient and long-lasting – developed and produced in a way that ensures they have a long lifetime. We use high-quality materials and offer the best light quality, always focusing on the benefit to the users.

Optimal lighting solutions for:

- **Conveyor belts and feed lines**
illumination and status or progress displays
- **Machines and processing centers**
illumination and state or progress displays
- **Workplaces**
illumination and state or hazard display

Our products for optimal lighting:

Machine lighting	Page 60
Signal lighting	Page 62
Signal lights	Page 64

To ensure trouble-free execution of all processes in production systems, optimal light is indispensable.

More info on
the topic here

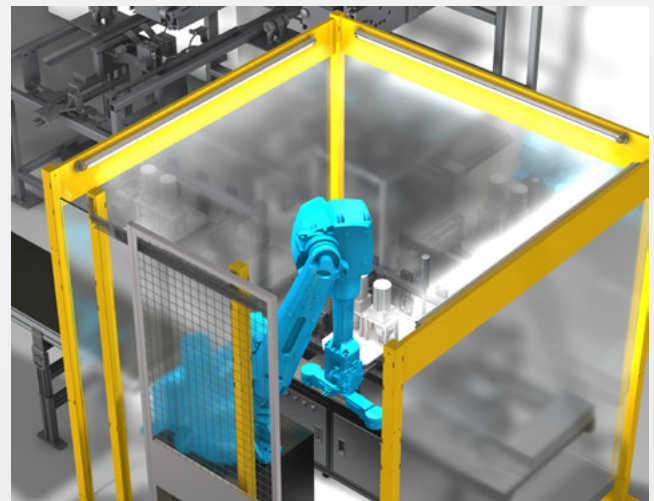



MULTIPLE TALENTS FOR MULTIPLE APPLICATIONS

The di-soric product portfolio

We would like to design the selection of the right product solution to be as comfortable as possible. In this brochure, you get an overview of our range of offerings. The depicted QR codes take you directly to the corresponding product groups on our website. Here our product selector and comparison is available to you – it has never been so easy!



Inductive sensors	18
Inductive proximity sensors	18
Inductive ring sensors	20
Inductive tube sensors	22



Optical sensors	24
Light barriers and diffuse sensors	24
Optical distance sensors	26
Fork light barriers	28
Angled light barriers	30
Frame light barriers	32
Plastic fiber optic sensors	34
Glass fiber optic sensors	35
High-performance light barriers	36
Light curtains	37
Optical label sensors	38
Color sensors	39
Contrast sensors	40
Optical motion sensors	41
Profile sensors	42
Line laser fork light barriers	43



Ultrasonic sensors	44
Ultrasonic barrier/sensors	44
Ultrasonic fork sensors	46
Ultrasonic label sensors	47



Capacitive sensors	48
Capacitive proximity sensors	48
Capacitive label sensors	49



Magnetic field sensors	50
-------------------------------	----



Image processing & identification	51
Handheld ID readers	51
Fixed-mounted ID readers	52
Vision sensors	54
nvision-i	56
Lighting for industrial image processing	58
Lenses	59

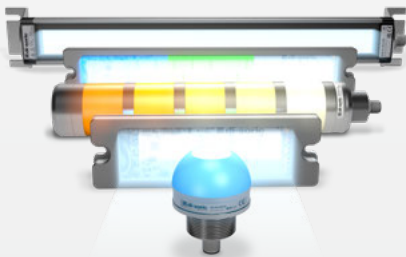

Machine lighting & signal lights	60
Machine lighting	60
Signal lighting	62
Signal lights	64



Accessories	66
Universal accessories	66
Product-specific accessories	67



INDUCTIVE PROXIMITY SENSORS

Inductive sensors play a crucial role in automation technology. They enable precise detection of metal objects without physical contact, at high switching frequencies and with high switching accuracy. Due to their insensitivity to vibrations, dust and moisture, inductive sensors from di-soric are maintenance-free, robust and have extremely long lifetimes.

Our inductive proximity sensors in several sizes help ensure the trouble-free execution of automation processes and maximize the efficiency and reliability of your automated systems.

In addition to the sensors for standard industrial applications, all-metal versions are available, pressure-resistant sensors up to 500 bar, as well as up to 3x or 4x switching distances. The list also includes sensors with an analog output for precise production or testing processes, welding field immune sensors, and sensors with IO-Link.

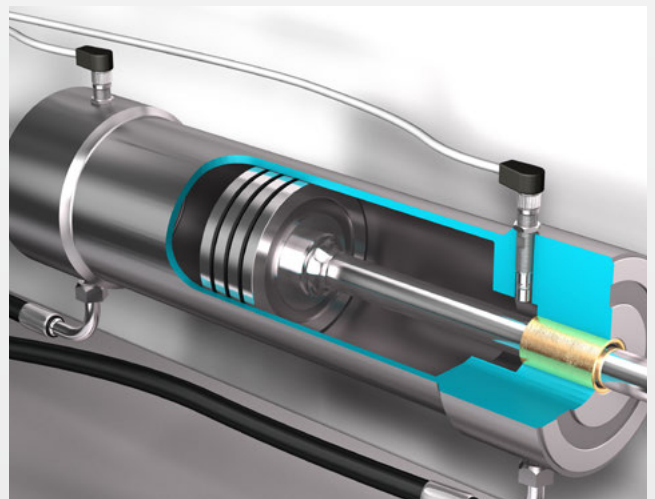

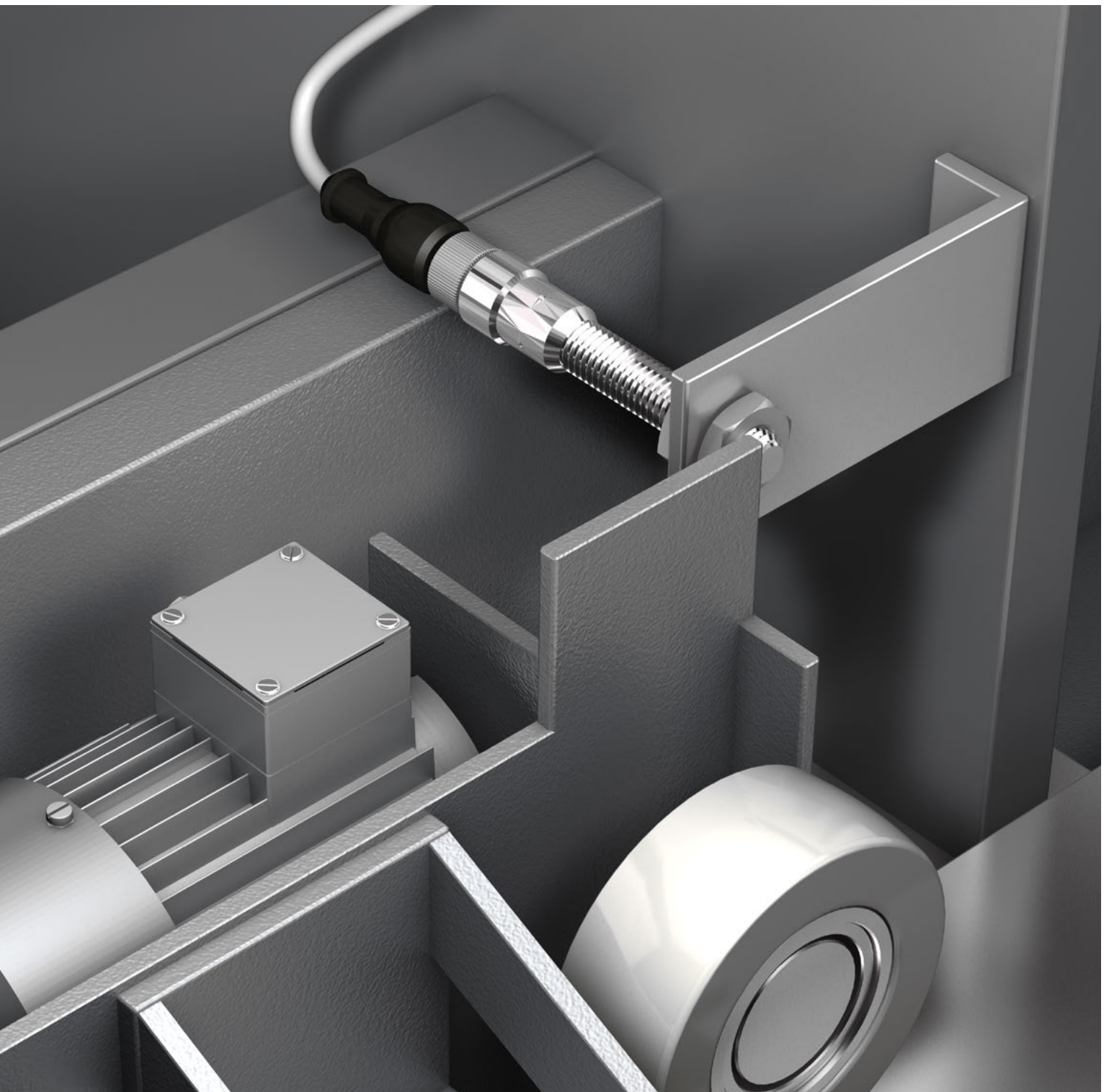

Series in focus

Special features

INS Standard	Suited for many standard applications, excellent price-performance ratio
INM Miniature	For the smallest and most confined installation spaces, excellent price-performance ratio
INE Industrial	For demanding applications, welding field immune versions
INW Full metal	For applications with high durability requirements or increased risk of mechanical contact, single all metal housing made of V4A stainless steel
INQ Cubic Model	For demanding applications, cubic models with 0.8 - 40mm switching distances
INP High pressure-resistant	For position monitoring in hydraulic systems or valve positions under high pressure up to 500 bar
INA Analog	For measuring the changes in distance of metal parts in which small changes in distance can affect the quality of the process
INH High-temperature-resistant	For ambient temperatures from - 25 °C to + 230 °C



INDUCTIVE RING SENSORS

Our inductive ring and wire breakage sensors with diameters from 4 to 151 mm detect the smallest metal parts that are conveyed in supply tubes for further processing. In the case of parts that are fed very quickly, the integrated pulse stretching generates an output signal that can be easily analyzed. Inductive sensors from di-soric are long-lasting and must only be exchanged relatively infrequently, since they are reliably protected against overload, short-circuit and polarity reversal.

Series in focus

Special features

IRB Standard	Static working principle, short response time, no adjustment elements, quick commissioning
IRSD Static/Dynamic	Multifunctional due to selection between NO/NC, static/dynamic operating principle, push-pull, pnp and npn, optimally adjustable to applications via IO-Link
IRDB Wire-break sensor	Detection of wire breakage

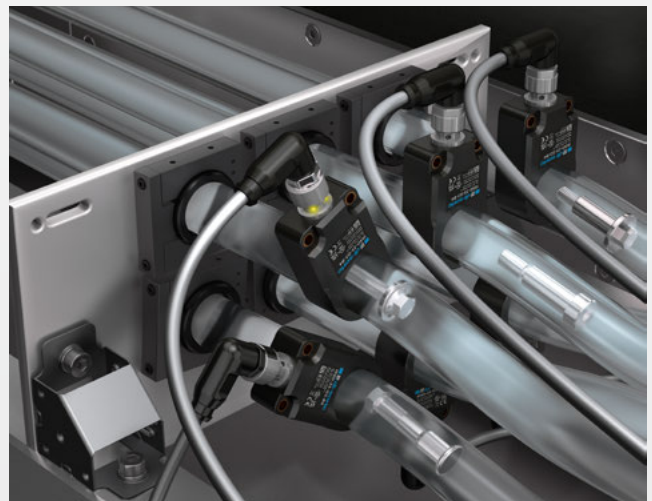

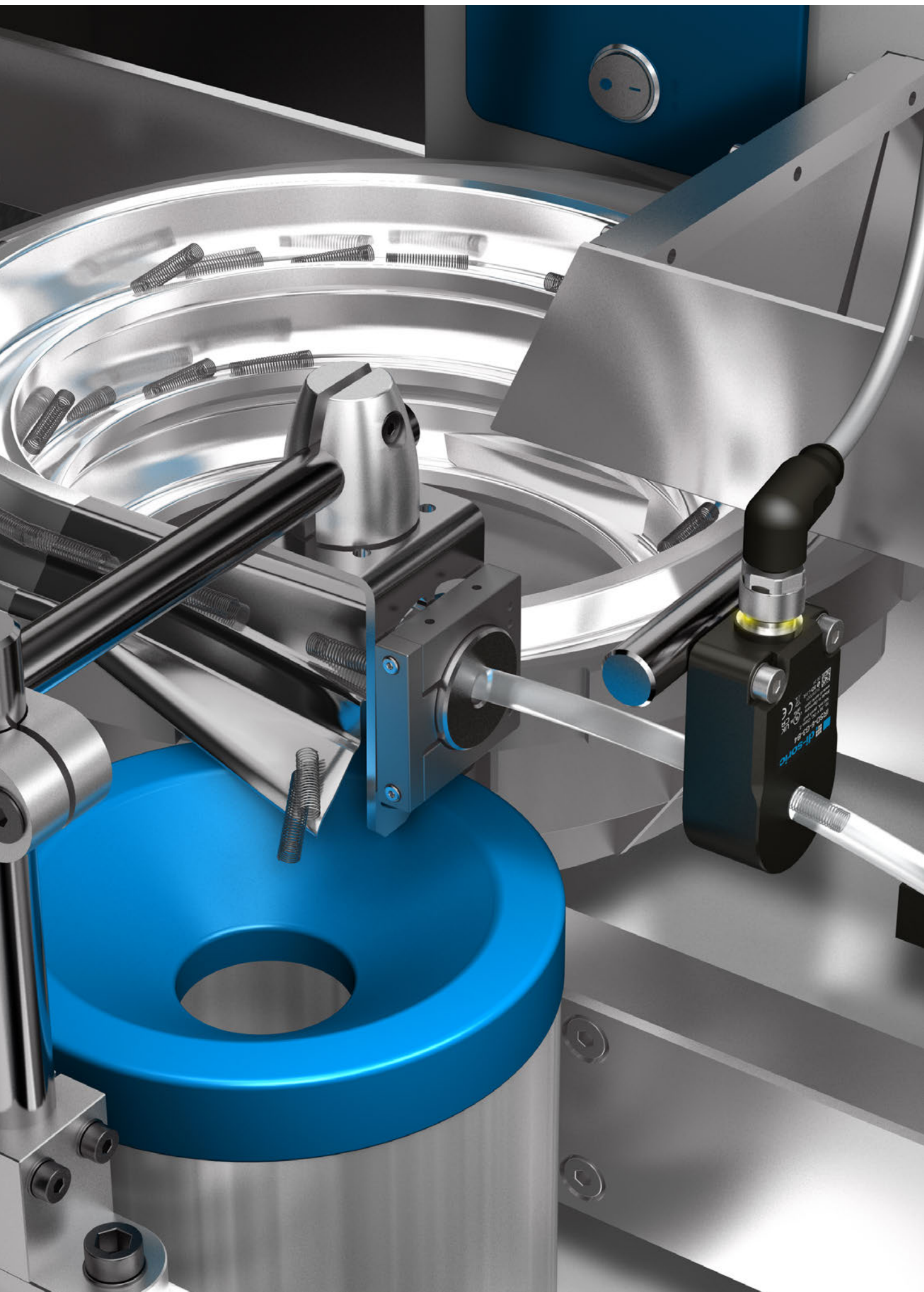



INDUCTIVE TUBE SENSORS

The area of deployment for our light and compact inductive tube sensors is the detection and counting of metal parts in supply tubes. The static and dynamic evaluation principle enables simple accumulation monitoring to be implemented. The compact sensors with a universal fastening system can be quickly adapted to different tube cross-sections without having to dismantle the supply tube.

Series in focus

Special features

IS Static

For detecting the smallest metallic parts, even ones that are fed quickly, as well as detection of material jamming

ISDP Dynamic

For applications that also require high resolution, short response time, and masking of metallic contamination



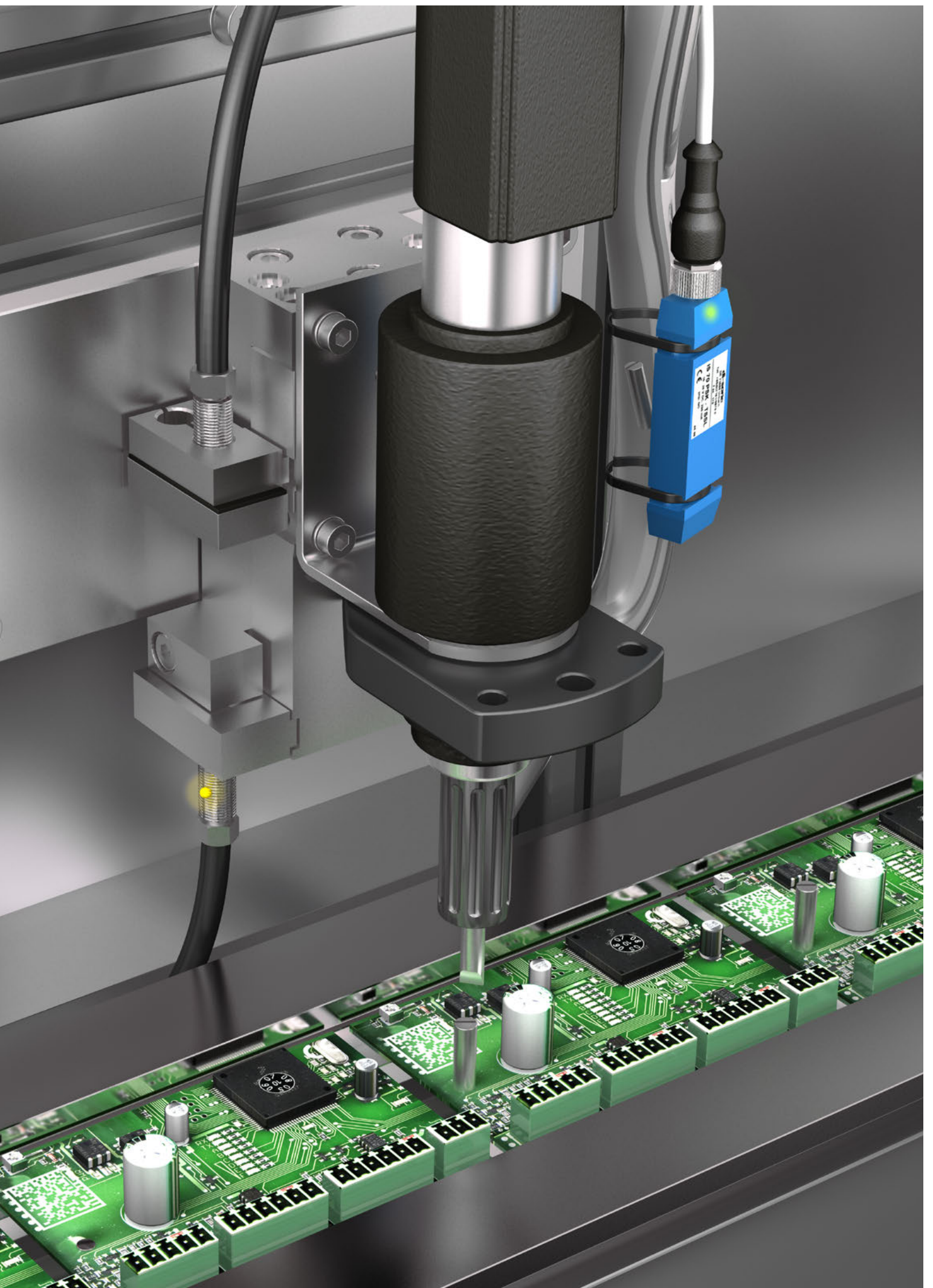



LIGHT BARRIERS AND DIFFUSE SENSORS

The light barriers and diffuse sensors from di-soric have been developed in several models and functional principles for many task areas in automation technology. The products are suited for fast, secure object detection and are distinguished by the highest functional safety.

Various operating principles, sensors, reflection or through-beam sensors are available.

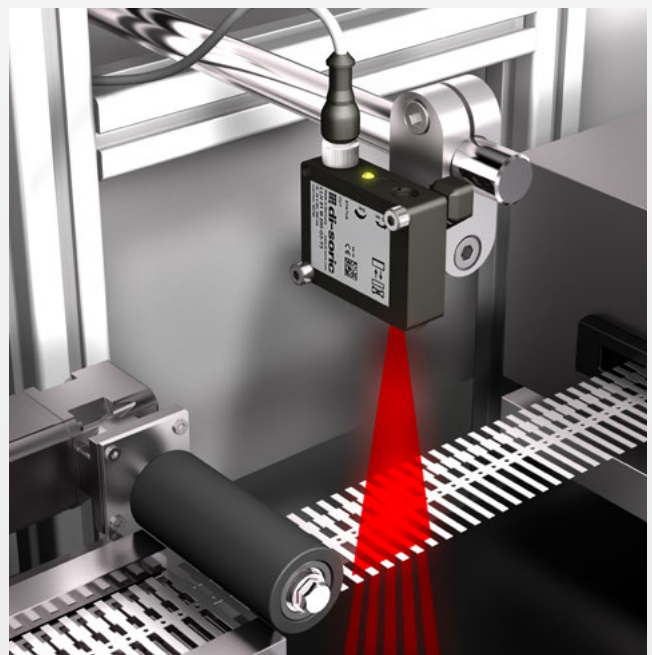
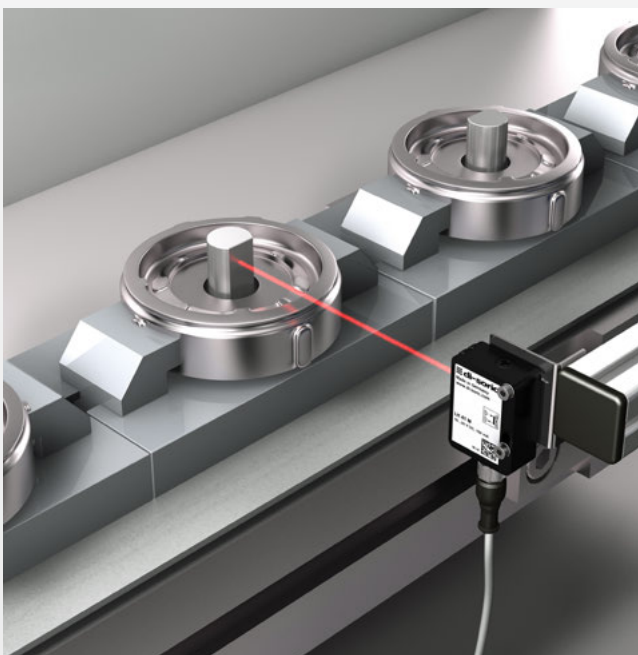

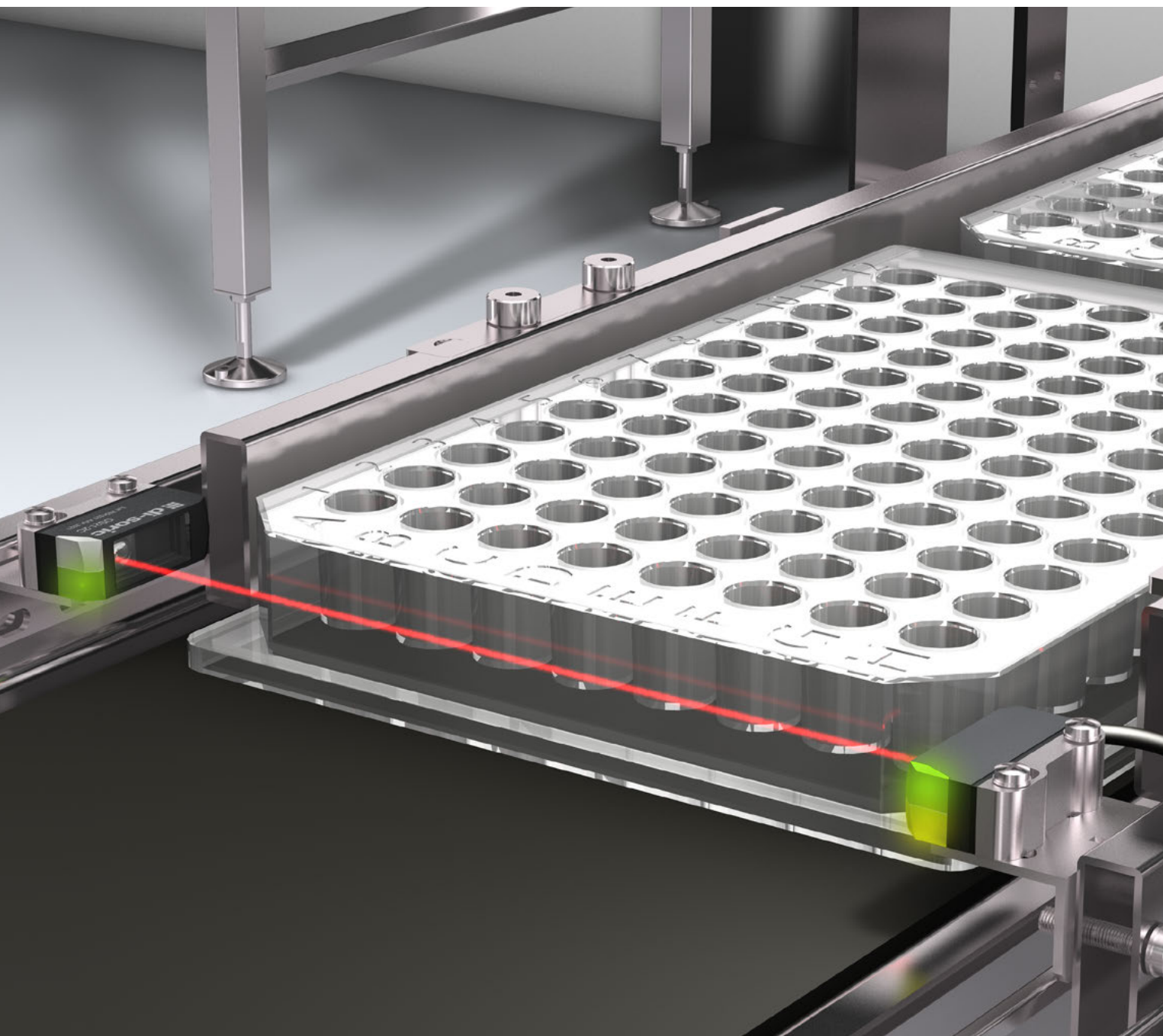

Series in focus

Special features

Series in focus	Special features
Cubic	O-20 Miniature Miniature sensors for confined installation spaces, as sensor, reflective or through-beam sensors
	O-21 Miniature Miniature sensors for small installation spaces, with IO-Link, also available as background suppression sensors
	O-30 Universal For many applications in packaging technology and assembly & handling technology, compact, with short response times and good functional reserves
	O-40 Standard For many standard applications with medium ranges
	O-40E Extended For detection of standard or small parts with medium ranges, with high resistance capability requirements
	O-50 Metal For long ranges, with maximum functional reserve, very robust
	O-81 Laser For precise detection of objects, with high resolution and functional reserve
	O-Q10 Miniature Compact laser through-beam sensors for the detection of small parts
Threaded	O-M5 Miniature sensors for precise object detection for assembly under confined space conditions
	O-M8 Compact laser light barriers for detection of small parts
	O-M18 Standard For standard applications with very good price-performance ratio
	O-M18E Extended For ambitious applications, with robust metallic housing, high functional reserve and high-performance background suppression
Cylinder	O-D4 Miniature sensors for precise object detection for assembly under confined space conditions



OPTICAL DISTANCE SENSORS

Optical distance sensors with red light laser are perfect for quick and precise distance measurements. With an impressive bandwidth of measuring ranges from 26 mm up to 10 meters, you will find solutions from us for various applications and production environments. For the highest precision in your applications, we have versions with a resolution up to the micrometer range in our product range.

Trouble-free commissioning is ensured by the intuitive and quick configuration at the sensor or via IO-Link. The robust metal housing makes our sensors especially resistant, even in the most challenging environments.

You can rely on optical distance sensors from di-soric ensuring precise measurements in various situations.

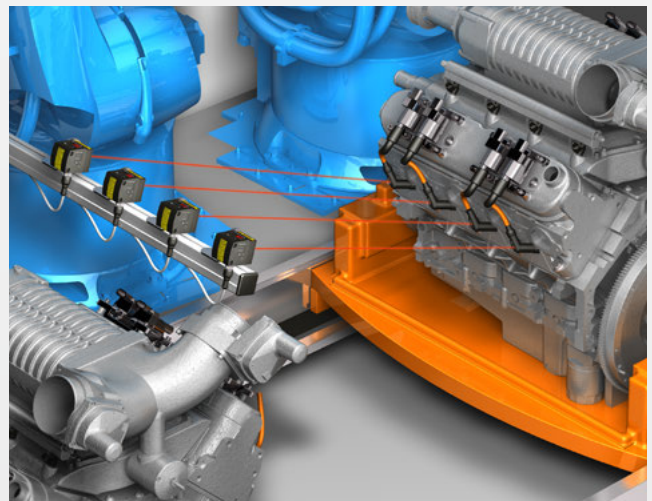
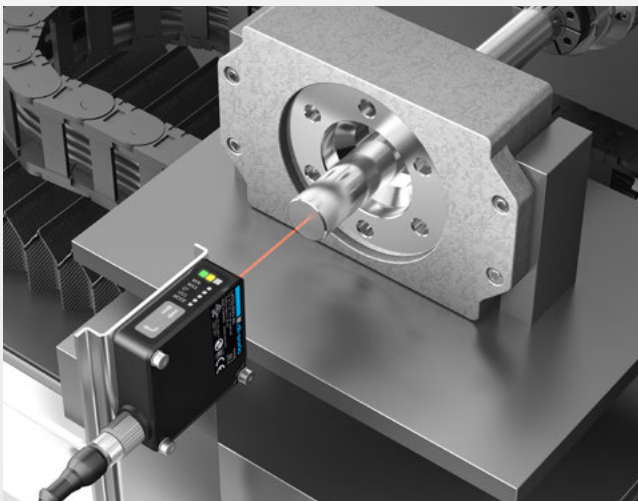

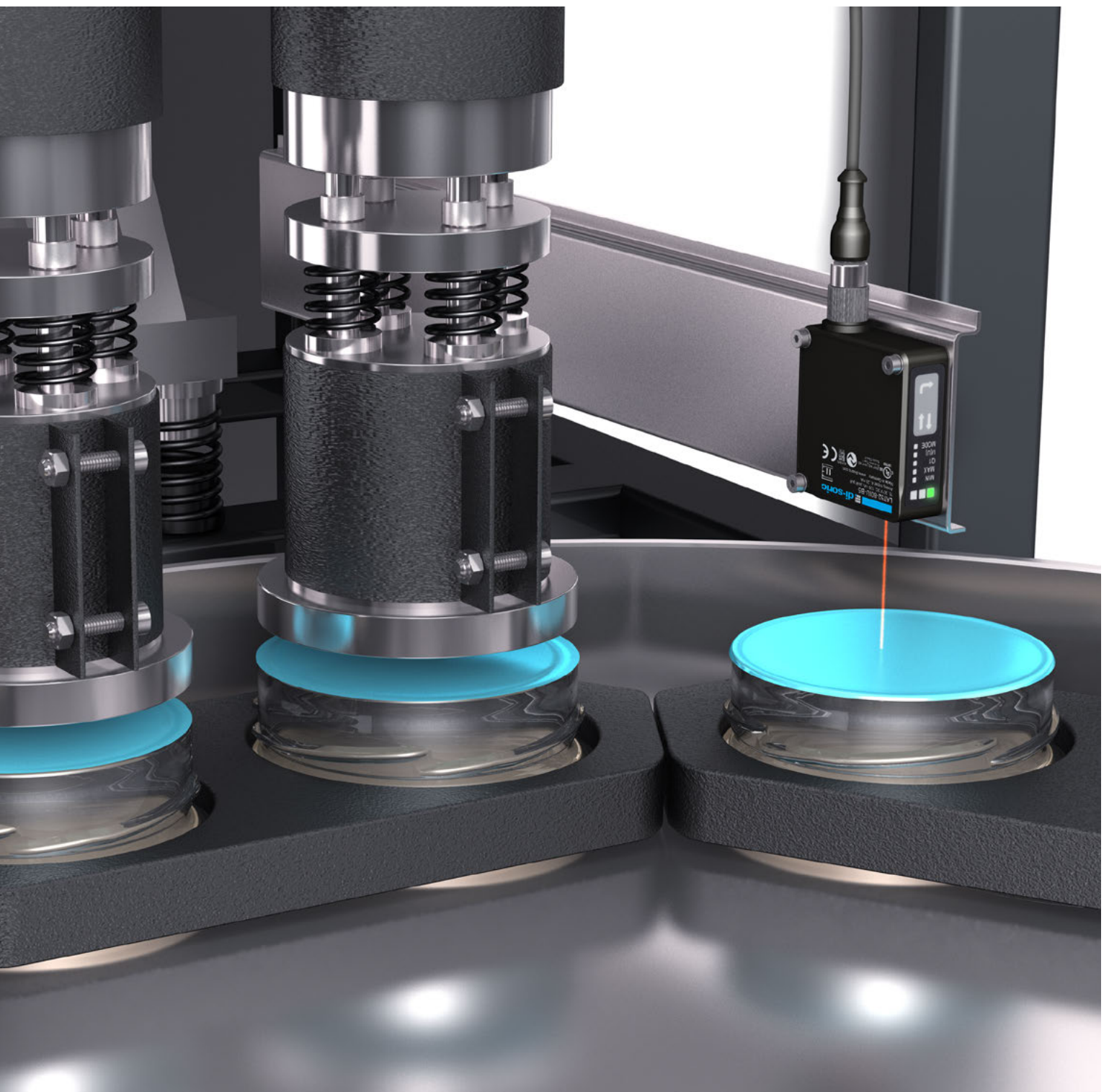

Series in focus

LAT-45 Long range

Special features

For measuring and switching applications with distances of up to 10 m

LAT-52 Compact

For applications in the mm and sub-mm range, distance up to 500 mm

VHT-52 Compact

For applications in which precise switching but not measuring is to be done, detection range from 50 to 500 mm

LAT-61 Precise

For highly precise, quick distance measurements into the micrometer range, measuring ranges from 26 to 180 mm



FORK LIGHT BARRIERS

For decades, di-soric has been developing fork light barriers that set new standards.

No application gets left out

Due to the variety of sizes and formats, the high resolution and quick reaction time, the various light sources – red light, infrared and laser – our fork light barriers enable optimal, process-reliable solutions – always tailored to the application and the available installation space.

Intuitive commissioning

Benefit from the usefulness of our fork light barriers with an innovative dual operation concept, either over IO-Link with the configuration of all sensor functions including 4 selectable sensor modes or through easy manual switch point adjustment with a potentiometer.

Application specific configuration instead of specific hardware

Instead of keeping various fork light barriers on hand for different applications, you can save the application-specific configuration, load it into the fork light barrier as needed or select the necessary sensor mode and get started right away. Device swapping works just as easily.

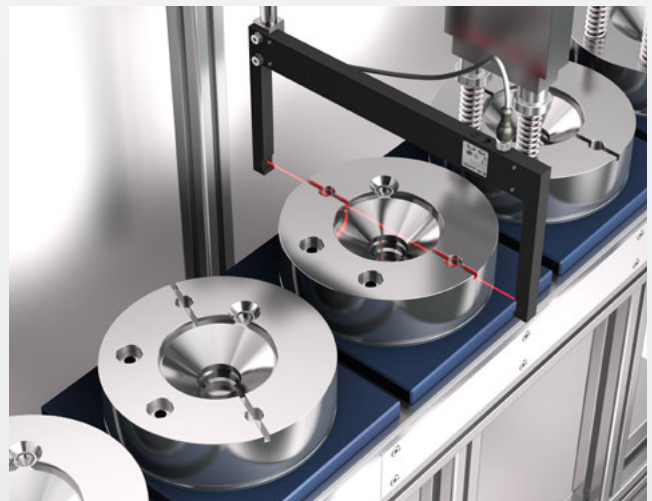
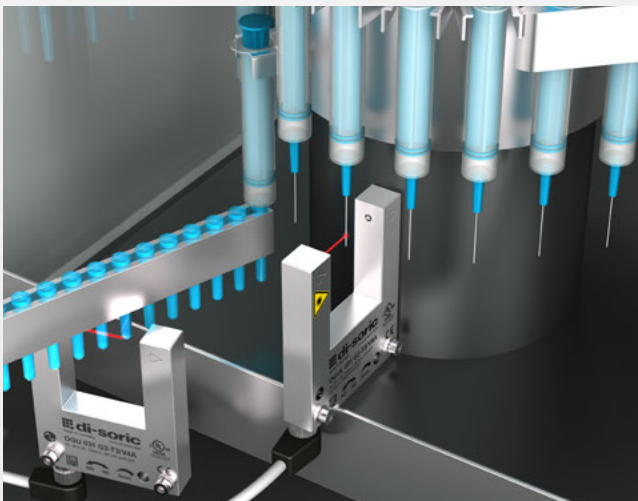

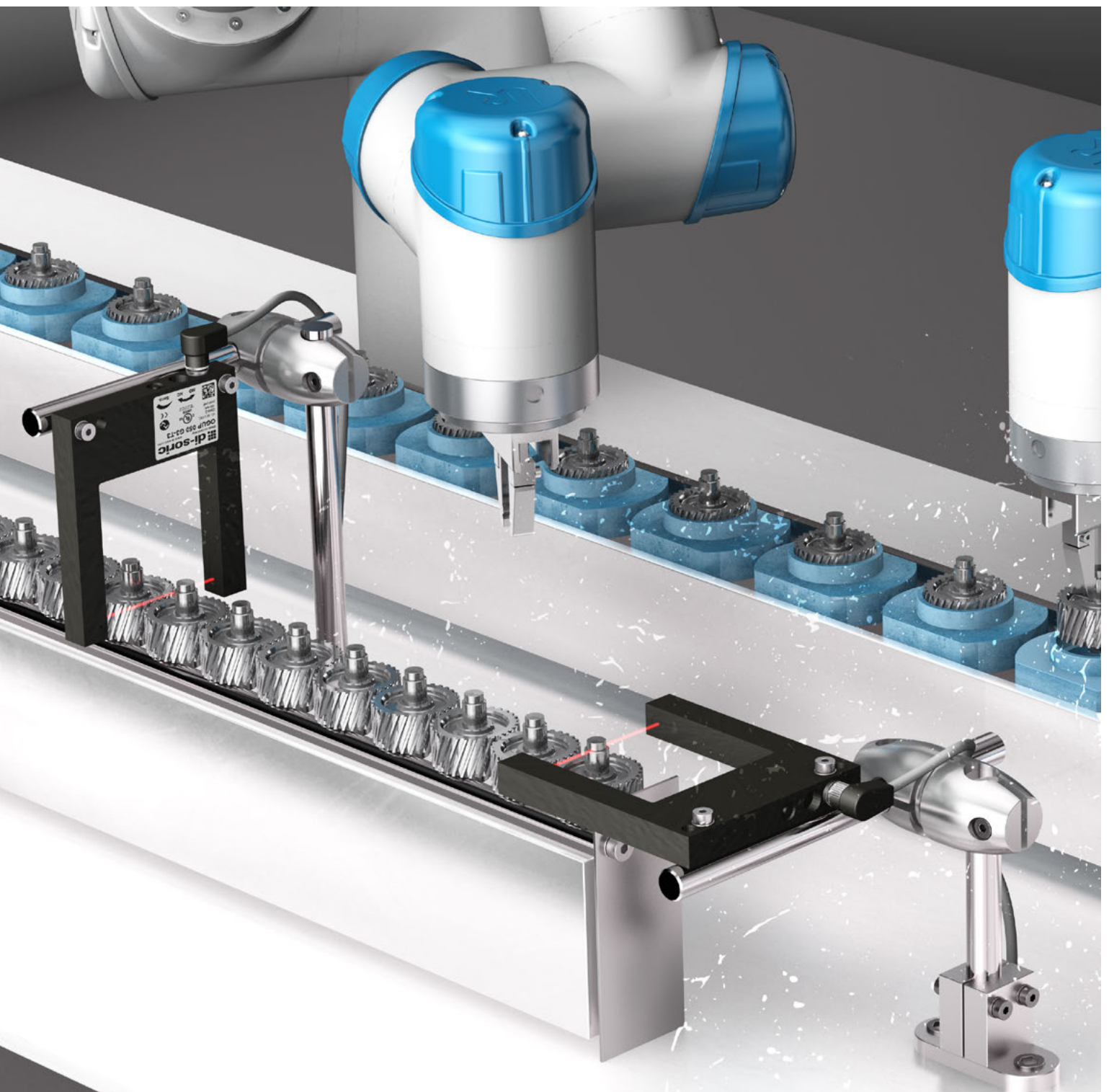

Sustainably long-lasting

All fork light barriers from di-soric have a metal housing – made of resistant alloys or stainless steel. They have high protection types, protection classes and approvals and are therefore sustainable solutions, robust and long-lasting.

Series in focus

OGU

Special features

Flexibly usable for many applications, with high resolution and reproducibility with outstanding speed

OGUP Dirt-resistant

With increased functional reserve, the cleaning cycles are reduced to a minimum

OGUL Laser

For the detection of the smallest parts from 0.05 mm, high precision over the entire fork width

OGU Stainless steel

For special requirements, can be cleaned simply and reliably with aggressive agents

OGUZ Special designs

For detection of glass-clear and very thin films



ANGLED LIGHT BARRIERS

The angled light barriers from di-soric are the ideal choice for quick and surface-independent object detection in confined installation situations. Their one-way principle ensures reliable performance: since transmitter, receiver and electronics are perfectly attuned to one another and unified in one housing. Angled light barriers are very simply and quickly mounted, and costly brackets and time-consuming adjustments are a thing of the past. You can rely on di-soric angled light barriers to increase the efficiency of your applications.

Series in focus

Special features

OGL	Flexibly usable for many applications, with high resolution and reproducibility with outstanding speed
OGLP Dirt-resistant	With increased functional reserve, versions with contamination display
OGLL Laser	For the detection of the smallest parts from 0.05 mm, high precision over the entire fork width

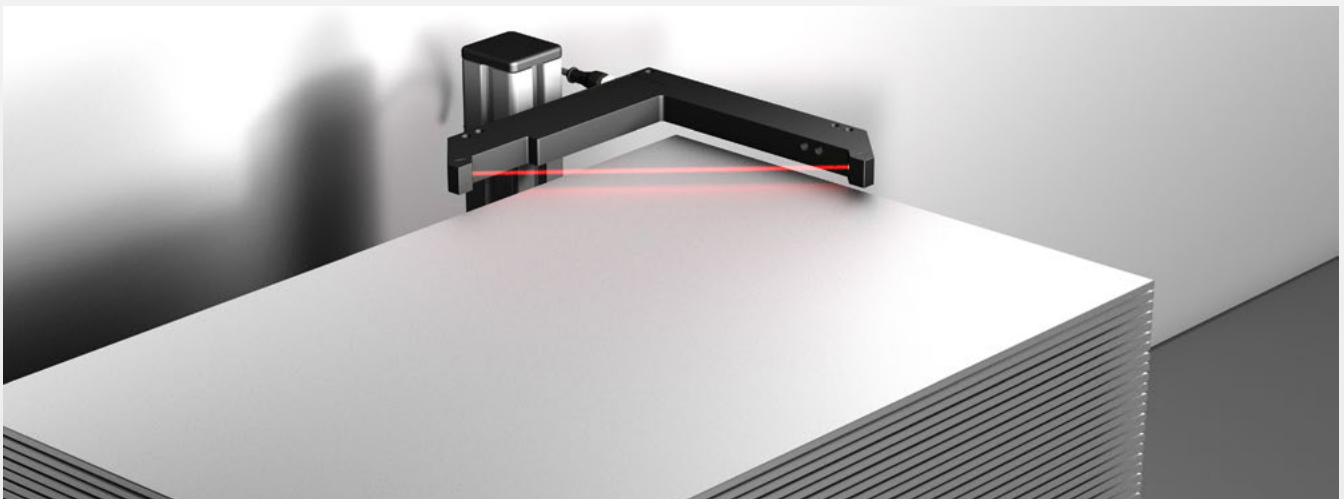

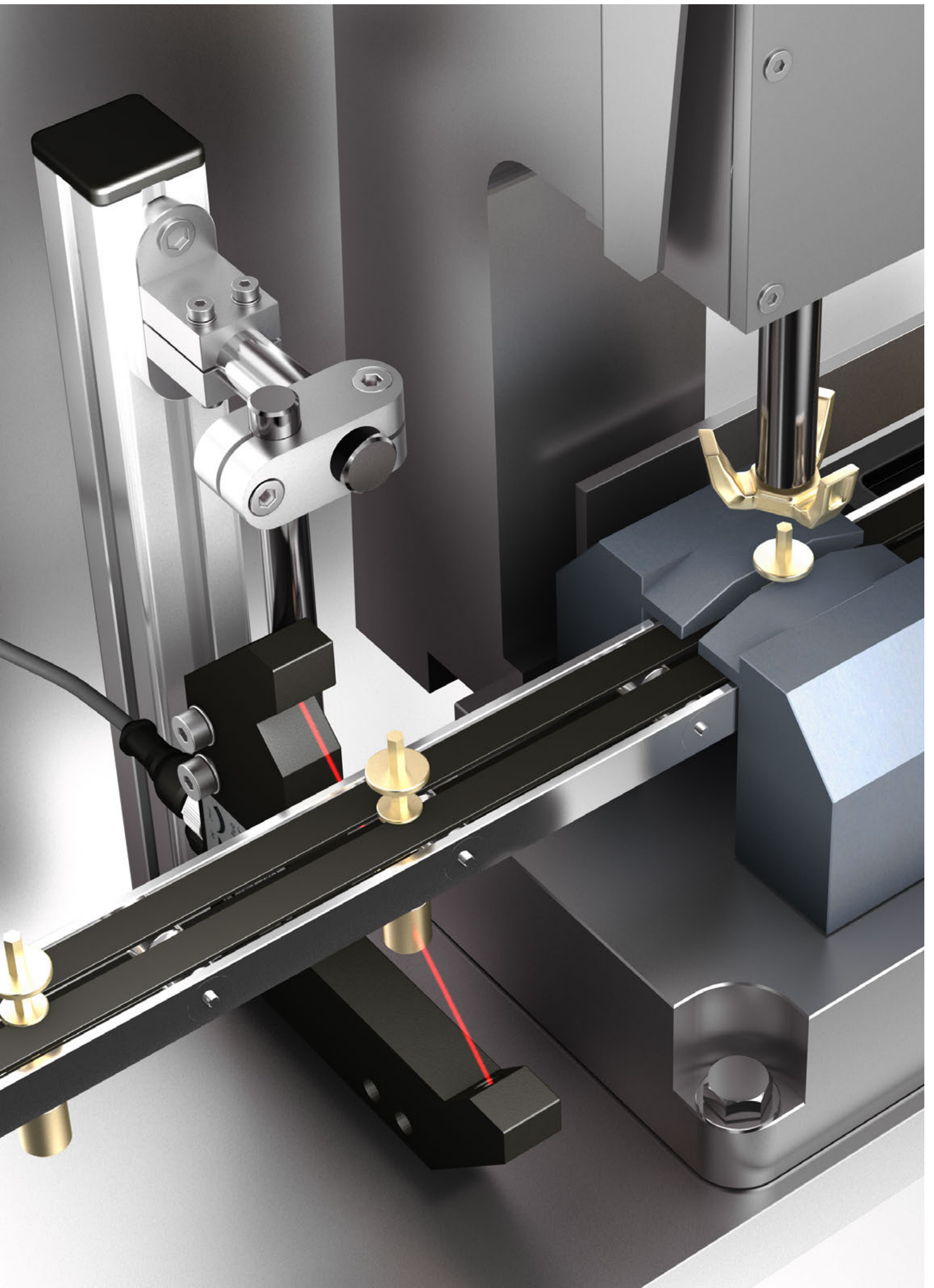



FRAME LIGHT BARRIERS

Discover di-soric frame light barriers – your solution for reliable object detection in a defined detection range independent of the position of the objects to be detected. Our frame light barriers offer a unique variety of sizes and models in order to satisfy nearly all application requirements in a large number of applications.

With static and dynamic object detection, our sensors can be used in extremely varied conditions. Through different sensor modes and the dual operating concept – configuration directly at the sensor or via IO-Link – the functionality of our frame light barriers can be adjusted to your specific requirements effortlessly and quickly.

The impressive high resolution and ultra-fast reaction time of our frame light barriers enables reliable verification and differentiation of even fast-moving objects. This makes them the ideal choice for precise feature checking, exact position checking, and reliable presence checking in your processes.

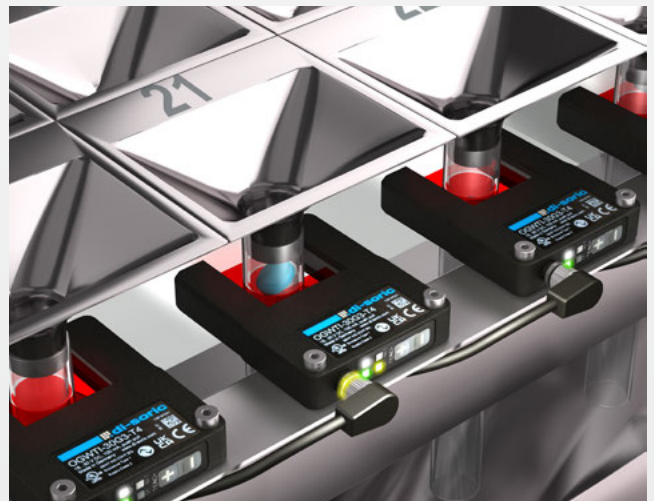
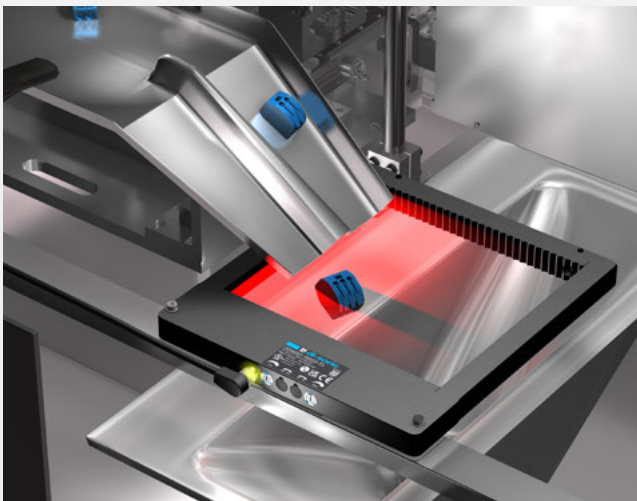

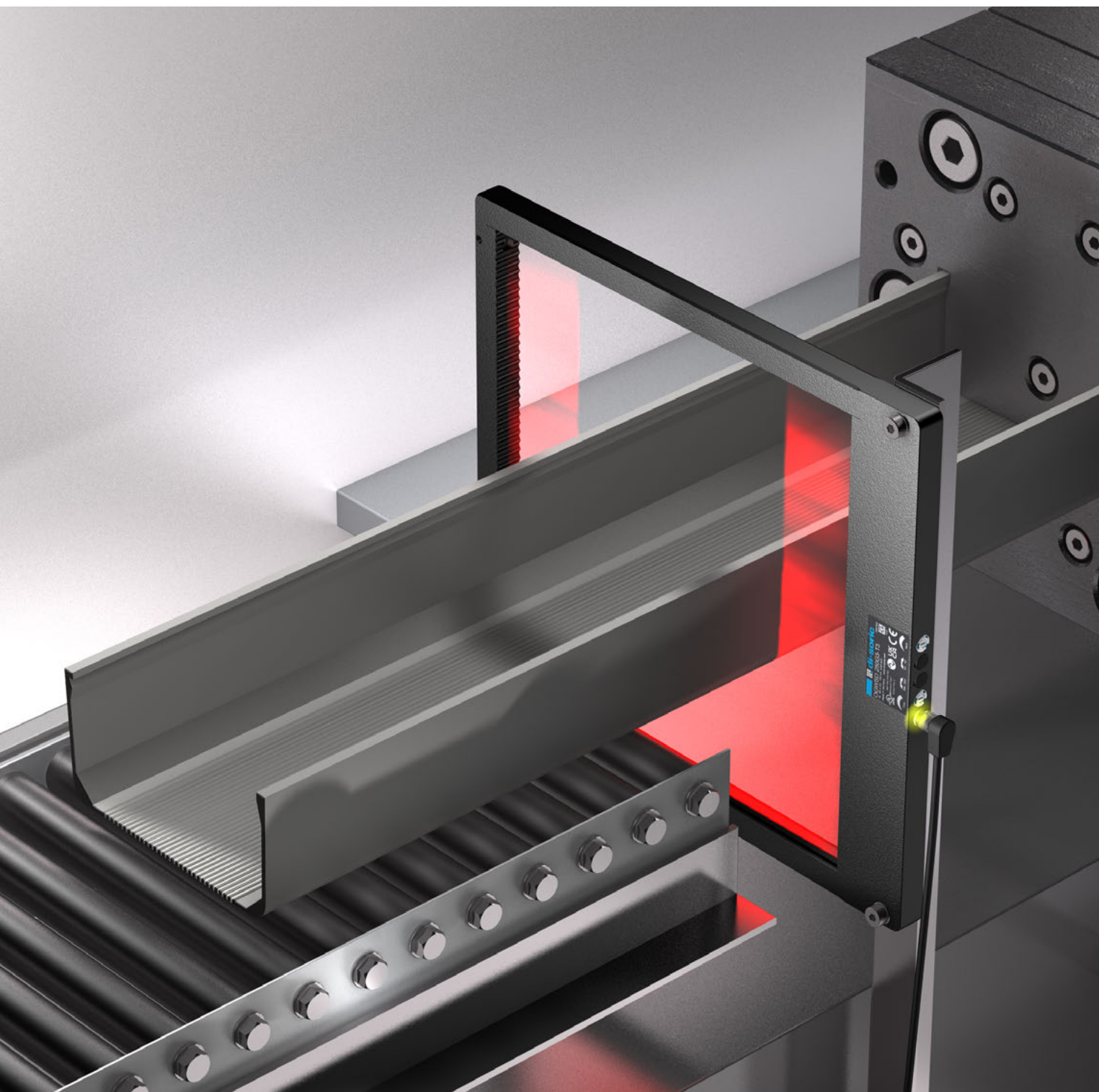

Not only the reliable detection of very small, quickly moving objects is of decisive importance in many applications: with our technology, frame light barriers offer a high functional reserve even if the lens is dirty, in order to ensure process-reliability.

You can rely on di-soric frame light barriers for precise and reliable object detection in a defined detection range.

Series in focus

OGWSD Frame design

Special features

For rough machine environments, with detection ranges up to 300 x 397 mm, 7 sizes, robust housing with impact protection, IO-Link

OGWTI Fork design

For installation in machines or on supplies, with detection ranges up to 100 x 100 mm, compact, open model, 4 sizes, IO-Link



PLASTIC FIBER OPTIC SENSORS

Our plastic fiber optic sensors are the ideal solution for applications in which the detection of small objects is required in confined assembly spaces. Thanks to our modular fiber optic and accessory product range, they can be adapted to your specific requirements. Top-hat rail assembly, in which the fiber optic amplifiers can be arranged in a row as desired, is especially practical. With our sensors, you are flexibly and optimally equipped for precise detection tasks.

Series in focus

OLV-K Amplifiers

Special features

For long ranges, simple to operate with maximum control, with time functions

KL Plastic fiber optics

With sensor probes for the most diverse kinds of applications, e.g. made of stainless steel with kink protection, sensor probes with light bands for range monitoring and fiber optics for the detection of the smallest parts

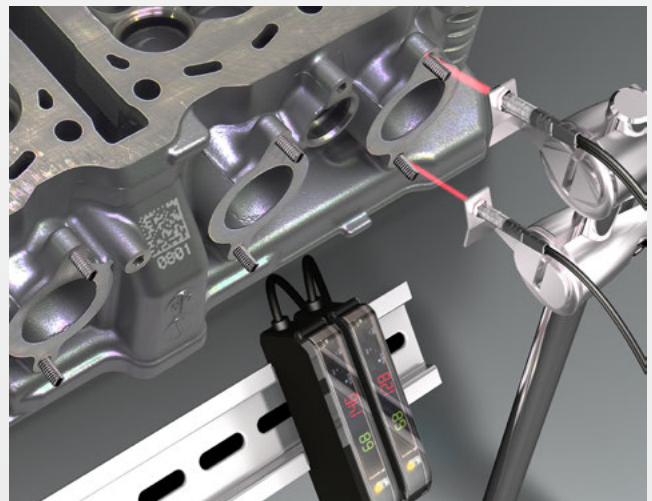
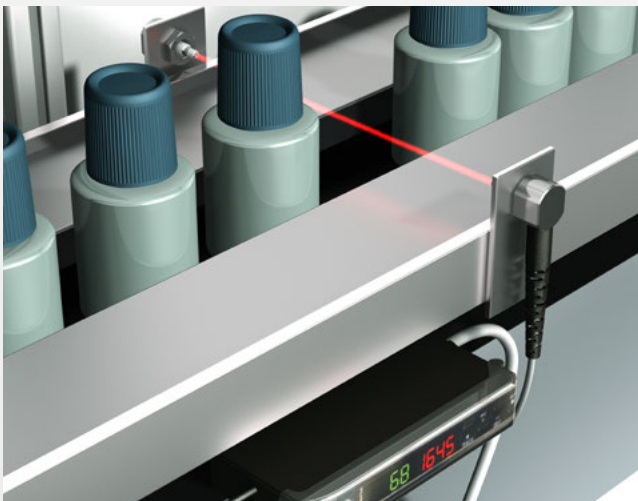

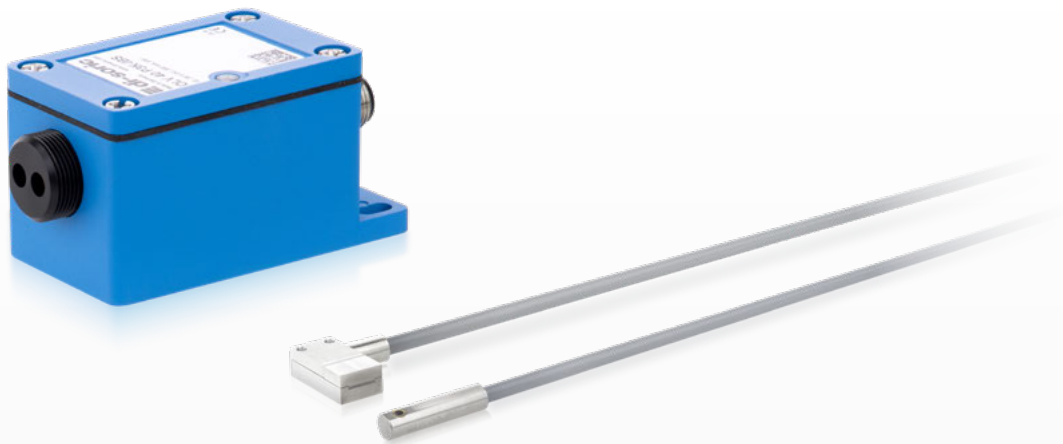

GLASS FIBER OPTIC SENSORS

Glass fiber optic sensors from di-soric have been specially developed for ambitious applications with confined installation space. These robust devices prove their reliability both in oily environments and even under extreme mechanical stress and high temperatures. One outstanding advantage is their impressive range, which provides the necessary flexibility in every situation.

Series in focus

Special features

OLV-G Amplifiers

For ambitious individual applications, with stable metallic housing and high protection class

WRB Glass fiber optics

High-quality fiber optics for large ranges, a high mechanical load and high temperatures

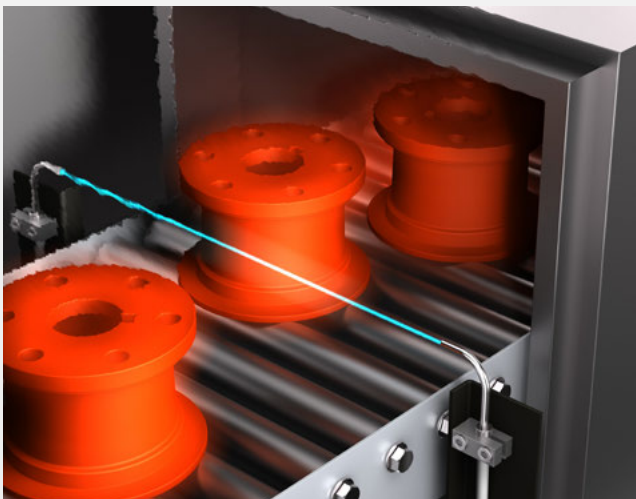



HIGH-PERFORMANCE LIGHT BARRIERS

Our high-performance light barriers are the perfect choice for ambitious applications. They are available in threaded and cubic models and can be combined with one another. These products effortlessly penetrate even heavy contamination, such as dust, oil and dirty water. Their safety is at the highest level, and they offer an impressive range of up to 50 meters.

Thanks to their robust metal housing, they are insensitive to vibrations and shaking. You can rely on our high-performance light barriers to satisfy your demanding requirements and to ensure the highest reliability.

Series in focus

Special features

OP-M12

For ambitious applications, threaded model M12, robust stainless steel housing

OP-Q12

For ambitious applications, compact cubic model Q12, robust metal housing

OP-50

For ambitious applications, cubic model, robust metallic housing, switchable transmission radiation angle, heating function

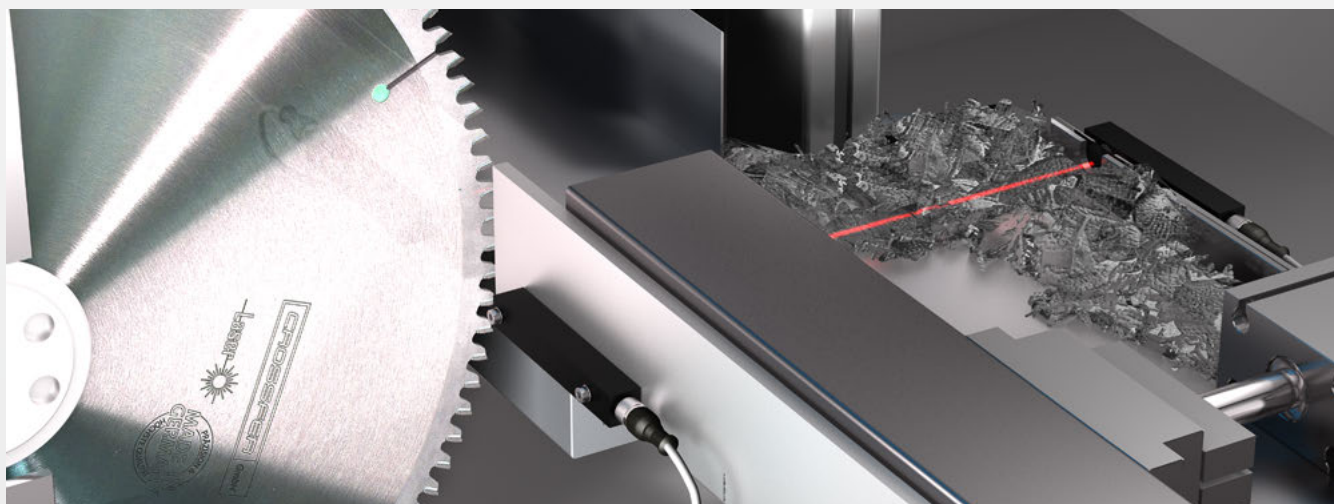

LIGHT CURTAINS



Our light curtains are specialists in object detection and measurement in large-area detection and measurement fields. They are based on an intelligent system of several through-beam sensors whose output signals can be linked together in order to achieve precise switching results, or which can be evaluated individually in order to perform detailed measurements. With different resolutions in many available sizes, our light curtains are extremely versatile and can be used in numerous applications.

Series in focus

Special features

LA Switching

For simple applications for object detection, with integrated switching outputs

LI Measuring

For ambitious measuring and detection tasks and object measurement, with high resolution and short response time

LI-A Evaluation electronics for series LI

Evaluation unit for one or two measuring light curtains LI, simple and fast integration in fieldbus environments

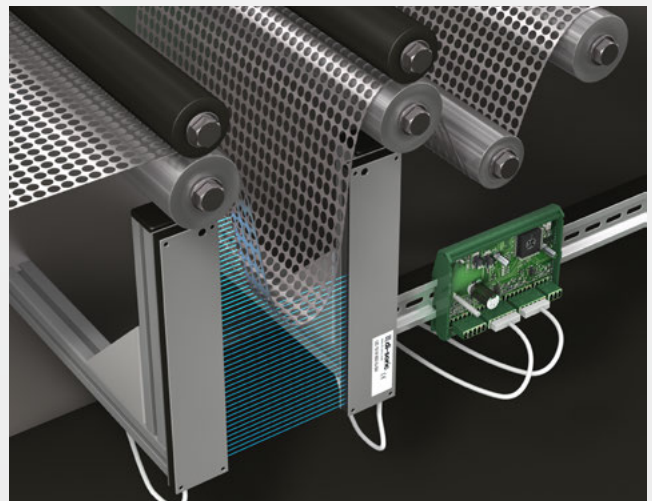
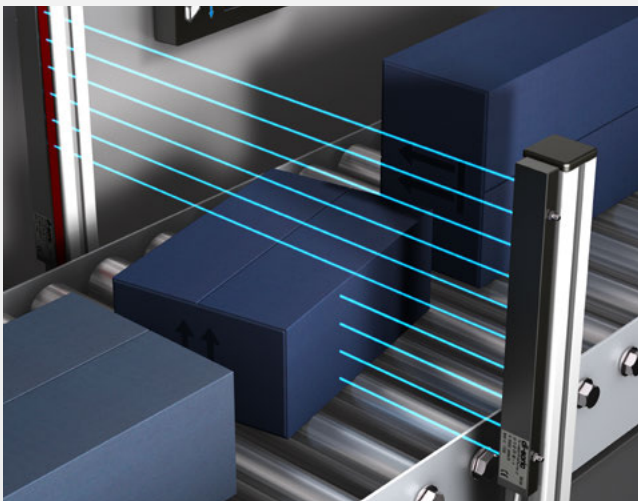



OPTICAL LABEL SENSORS

The optical label sensors from di-soric are the perfect solution for the fast and precise detection of thin and thick paper labels. With their impressive dispensing precision and reproducibility, they enable maximal belt speeds.

Series in focus

OGUTI

Special features

For the highest dispensing precision and reproducibility at maximum belt speeds, with large functional reserve

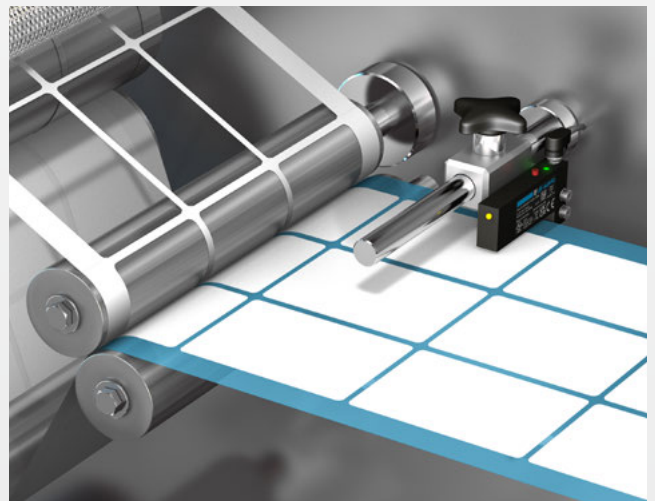



COLOR SENSORS

The di-soric color sensors are specialists in safe and reliable color detection. With their capacity to identify colors and compare them to up to 100 saved reference color values, they can be used in various ways. Thanks to their perceptive working mode, which is similar in function to that of the human eye, even the finest color nuances can be detected precisely. This makes them indispensable tools in quality inspection, even under challenging industrial conditions.

Series in focus

Special features

FS-10 Compact	For the differentiation of the finest color nuances under confined installation conditions
FS-50 Extended	For the precise differentiation of up to 15 saved colors, with fiber optic connection or fixed optics, versions with configuration that can be reproduced via software
FS-100 Advanced	For the precise differentiation of up to 100 saved colors, with fiber optic connection, reproducible configuration via keys or software, versions with Ethernet and PROFIBUS enable digital data transmission of process and color values.

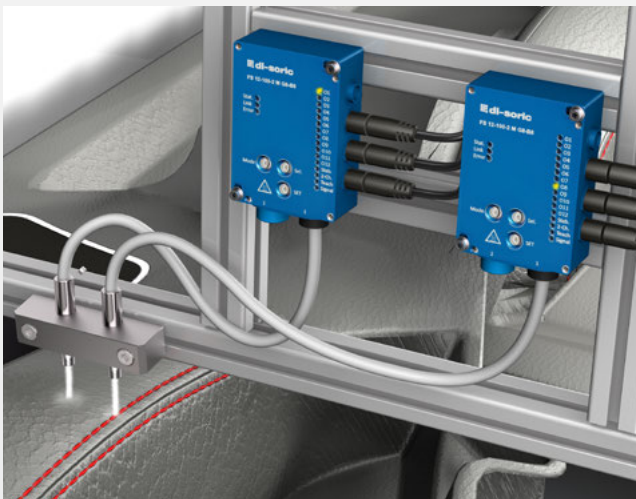



CONTRAST SENSORS

Our contrast sensors detect and compare contrasts very precisely. With them, you can reliably and precisely detect printed markings on various carrier materials such as labels, films, banderoles, cartons or tubes, based on color or grayscale contrasts. The configuration of these sensors is simple and intuitive, so that you can teach them in without problem.

Series in focus

OK-50

Special features

For the detection of the finest contrasts, even under challenging ambient conditions

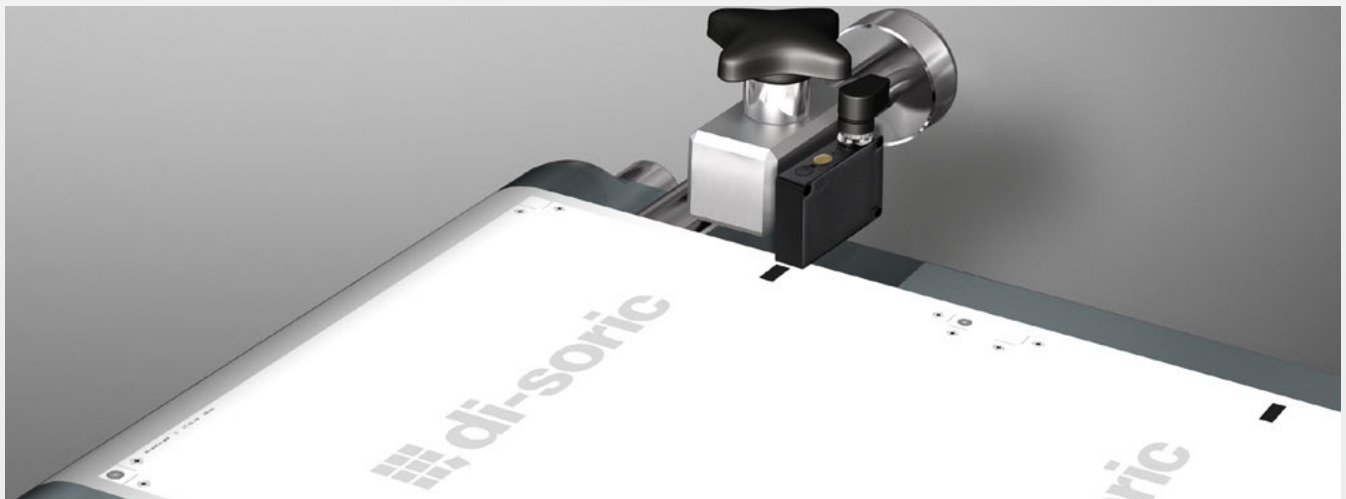



OPTICAL MOTION SENSORS

Our optical motion sensors are the perfect solution for detecting feed and rotary movements of various materials. With their ability of contactless feed control, even at low speeds and with wires, they can be used in a variety of ways. These sensors detect movement or stopping on metal, non-metal and shiny surfaces and always supply, thanks to the adjustable impulse elongation, a stable signal. With their compact form and the robust metallic housing, they are the ideal choice for ambitious applications.

Series in focus

OBS

Special features

For differentiating between movement and standstill in the near range, even at low speeds and for wires, for example, feed control, optionally with the detection of movement direction





PROFILE SENSORS

Our profile sensors use the advanced light section procedure in order to precisely compare the profile of the object to be inspected with an already taught-in target profile. Thanks to their color and ambient light sensitivity, even the smallest differences can be detected, even if nearly identical components are involved or the lighting conditions and object colors vary. Our sensors are therefore perfectly suited for quality inspections in which the highest degree of reliability is required.

Series in focus

PS-30 2D Laser profile sensor

Special features

For surface-independent inspection and measurement of the profiles of various objects via laser line scan, e.g. in assembly lines for quality inspection

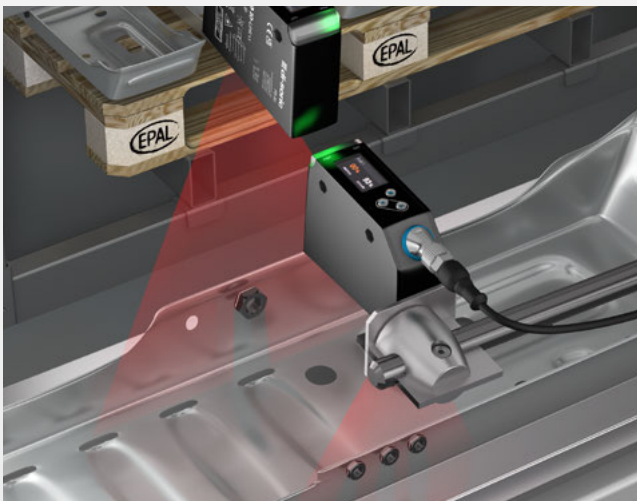



LINE LASER FORK LIGHT BARRIERS

Our line laser fork light barrier works with a fine laser light band that ensures high resolution over the entire detection range. It is therefore the perfect solution for high-precision edge measurements and the exact determination of diameters in manufacturing and quality control.

The measured data are transmitted via the analog output for further evaluation.

Series in focus

LLGT Measuring

Special features

For precise edge measurement and the determination of diameters, high resolution, with analog output

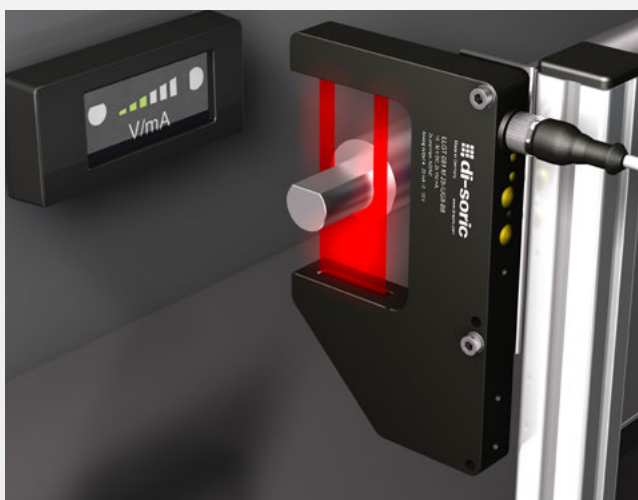



ULTRASONIC BARRIER/SENSORS

The innovative ultrasonic barriers and sensors in the US series distinguish themselves with their reliable detection of transparent, bright and dark, as well as reflective objects. These sensors are the perfect choice, even in challenging environments in which dust and dirt present a challenge. We also offer you sensors with an IO-Link connection for even more comprehensive control and integration in your processes.

Series in focus

Special features

US-M8	For the highest degree of flexibility at short ranges and in confined installation spaces, optimal for the modernization of systems
US-M12	For measuring or switching applications, compact, with teach-in and IO-Link, operational within seconds
US-Q12	For measuring or switching applications with shallow installation depth, compact, with teach-in, potentiometer and IO-Link
US-M18	For medium ranges up to 1,500 mm, switching or measuring
US-M30	For medium ranges up to 6,000 mm, switching or measuring

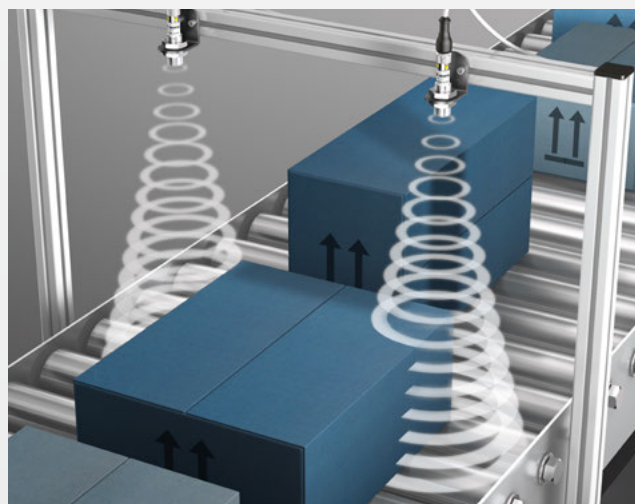
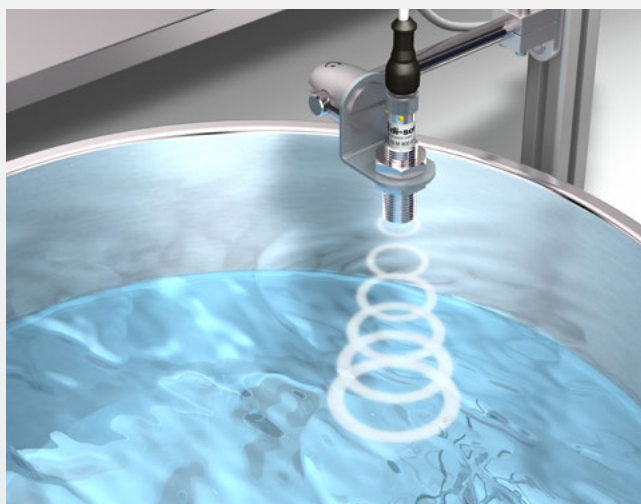

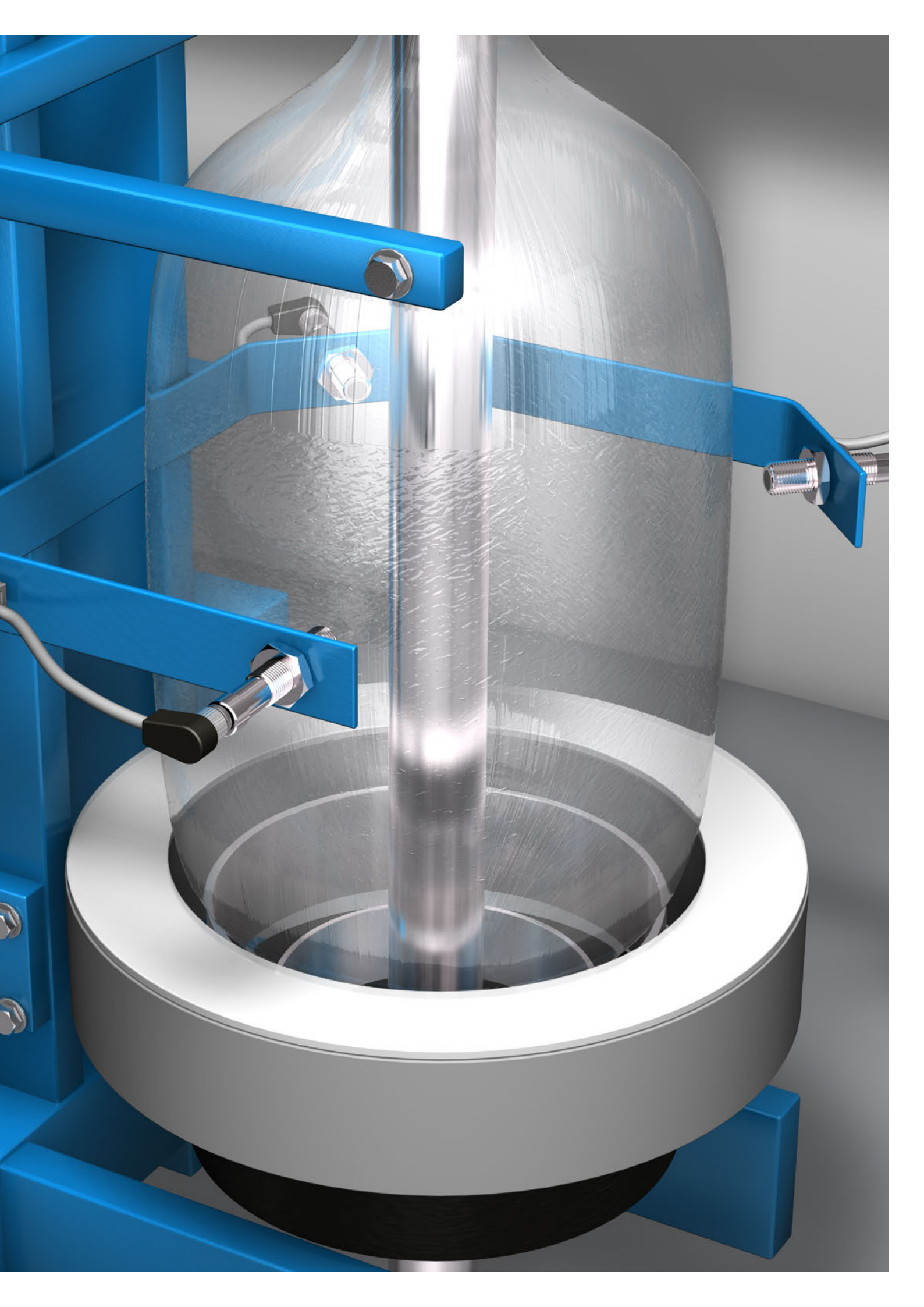



ULTRASONIC FORK SENSORS

Our ultrasonic fork sensors are the ideal solution for precise position determination of sheet edges in the case of films and paper, regardless whether they are transparent, non-transparent or reflective. These calibrated sensors satisfy nearly all application requirements for precision with their impressive repetition precision.

The reliability of our sensors is unmatched, because they are insensitive to dirt and resistant to the harshest conditions. The robust metal housing with a high protection class ensures that our sensors deliver the desired results in every environment and in every application. You can rely on di-soric ultrasonic fork sensors when you need reliable precision for your sheet edge control.

Series in focus

USGT

Special features

For position determination of sheet edges with films and paper, with very high repetition accuracy, dirt-insensitive

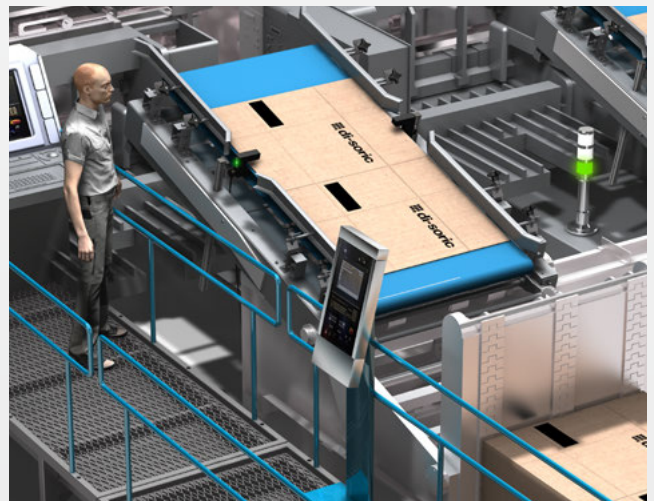
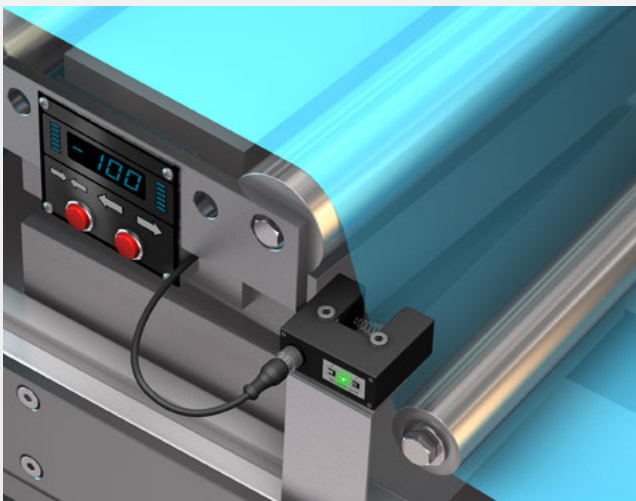



ULTRASONIC LABEL SENSORS

Our ultrasonic label sensors are extremely versatile and can be used with various label materials without problems. They can reliably detect not only thin and thick transparent, film, and paper labels, but metallic labels as well. With their innovative dual operating concept, in which the operation can be performed optionally via IO-Link or teach-in, they enable quick commissioning of the sensors.

Series in focus

UGUTI

Special features

Universally suited for various label materials, such as thin and thick transparent, film, and paper labels and metallic labels





CAPACITIVE PROXIMITY SENSORS

Capacitive proximity sensors from di-soric are ideally suited for contactless, precise detection of liquid, powdered and solid objects and bulk materials. They offer reliable detection of metallic and non-metallic materials, even through container walls or packaging. Due to the insensitivity to disruptions such as light or dirt, they are also excellently suited for challenging production environments.

Series in focus

KNS Extended

Special features

For the detection of liquid, powdered and solid materials, as well as metallic and non-metallic parts, with IO-Link, available with switching distances from 2 to 8 mm

KDC Standard

For the detection of liquid, powdered and solid materials, as well as metallic and non-metallic parts, available with switching distances from 2 to 3 mm

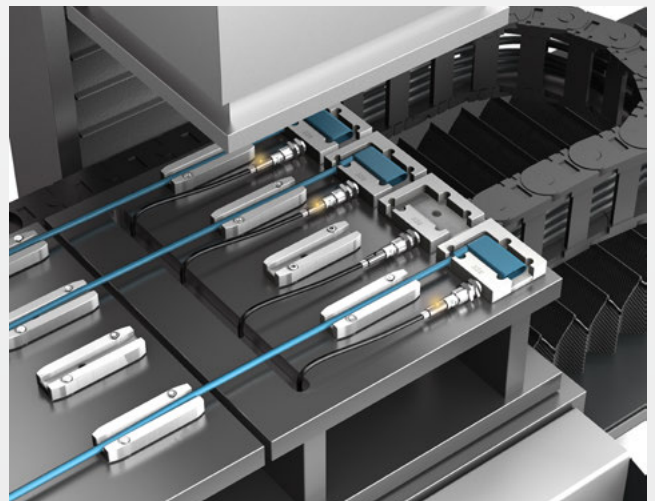
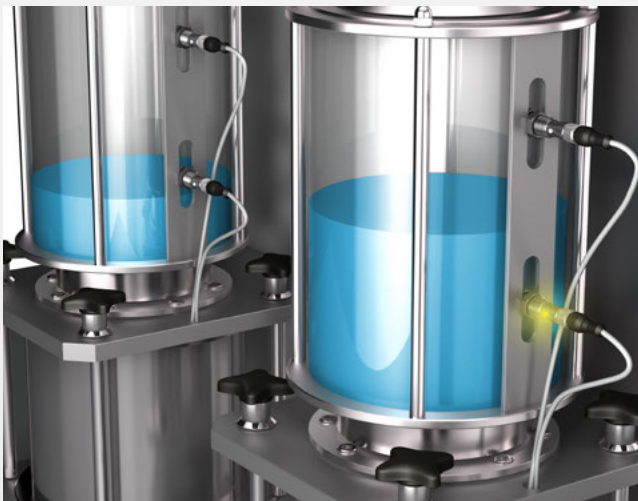



CAPACITIVE LABEL SENSORS

Capacitive label sensors are the cost-effective and high-performance solution for position detection of thin, transparent, foil and paper labels. They show their strengths particularly well wherever high tape speeds are required. Using auto-teach, they are taught in to new materials quickly and intuitively.

Series in focus

KGUTI

Special features

For the detection of thin transparent, film and paper labels and particularly where high belt speeds are required





MAGNETIC FIELD SENSORS

Our magnetic field sensors were specially developed for pneumatic cylinders with integrated magnets and offer precise detection of the piston position through the cylinder wall. They are the ideal solution for applications in which precise position feedback is of decisive importance.

Increase the efficiency of your pneumatic systems and minimize the downtime with our magnetic field sensors designed for reliability and long life.

Series in focus

Special features

MZEC Cylinder sensors C-groove	For all common pneumatic cylinders with installed magnets, wear-free
MZET Cylinder sensors T-groove	For all common pneumatic cylinders with installed magnets, wear-free
MZEK Cylinder sensors T-groove	Can be inserted from above into the T groove and are therefore especially well-suited for subsequent exchange of a cylinder
MZES Gripper sensors	For use on gripper tongs, with specially aligned magnetic field
MZEKS Gripper sensors	In short design with high protection class, for use on gripper tongs, with specially aligned magnetic field

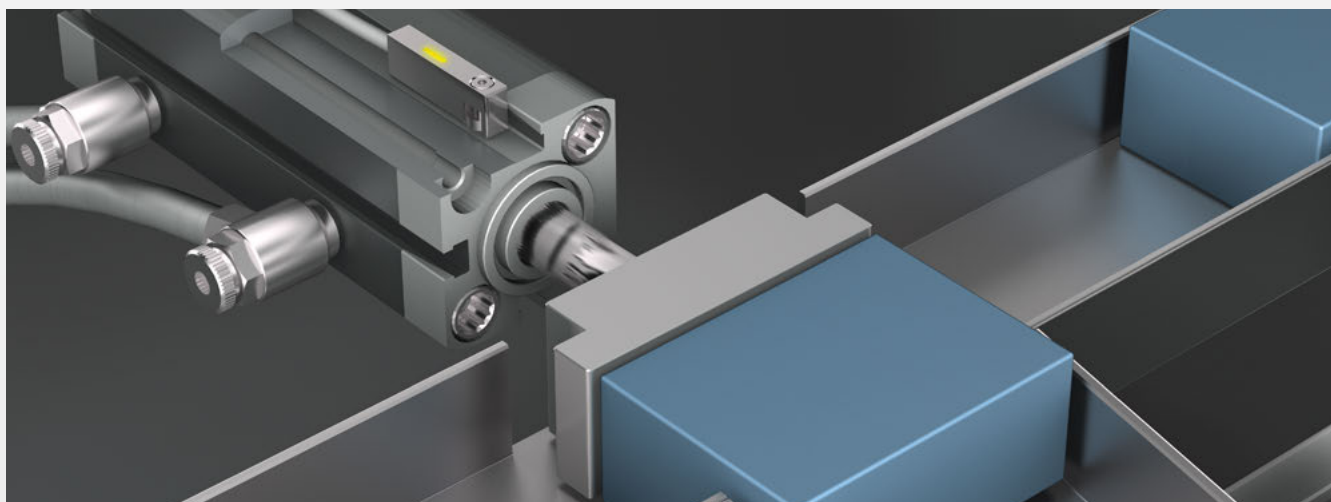



HANDHELD ID READERS

In most industries, data must be captured quickly, reliably and flexibly. In this context, the handheld ID readers from di-soric are the ideal solution. Our automatic scanners read and decode 1D and 2D codes in any process environment, in order to accelerate your processes and make them stable.

Series in focus

ID-10 Compact

Special features

For the detection of common 1D and 2D codes in less challenging process environments and confined spatial conditions

ID-80 Standard

For the detection of common 1D and 2D codes in less challenging process environments

ID-100 Advanced

For the detection of 1D and 2D codes in challenging process environments with increased requirements for readability of directly marked codes (DPM) that are difficult to read

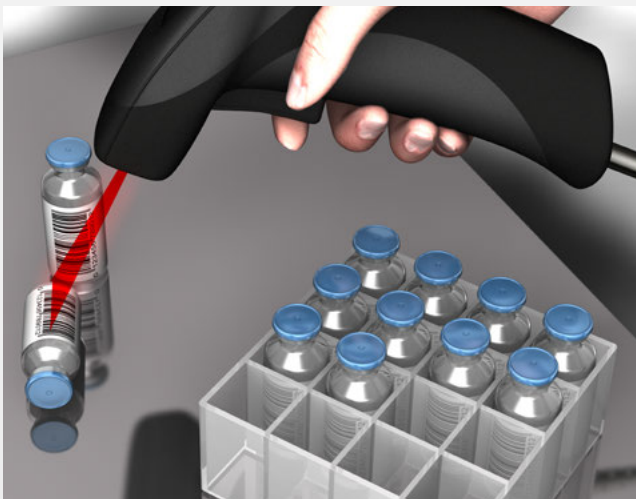



FIXED-MOUNTED ID READERS

Fast, reliable reading and identification of ID codes of virtually any type is a basic requirement for efficient operations and high productivity in numerous production, conveying, and logistics processes. Modern identification systems are used in applications such as identifying and tracking components, products and packaging. In doing so, they link the flow of information with the flow of materials. Ideally, they detect the type and condition of the conveyed material at any time and at any desired location and can thus influence the corresponding production segment in a versatile and process-optimizing manner. Identification solutions such as the ID-600 fixed-mounted ID reader thus form the basis for highly automated production.

The ID-600 solves a broad spectrum of ambitious code-reading applications: It recognizes common 1D, 2D as well as DPM codes even at long distances and under adverse ambient conditions. Four interchangeable lenses with different focal lengths and software image correction ensure high image quality and reliable results in flexible production systems. The versatile ID reader can be easily installed and is ready to use quickly: Using the intuitive nVision-i software, even non-programmers can get the ID-600 up and running in no time, even in existing systems.

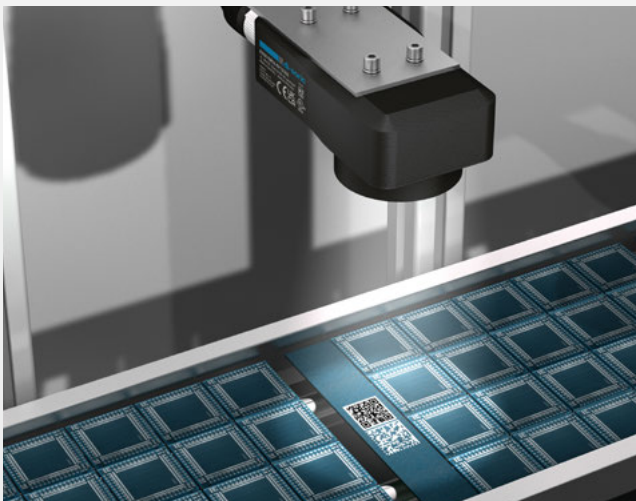

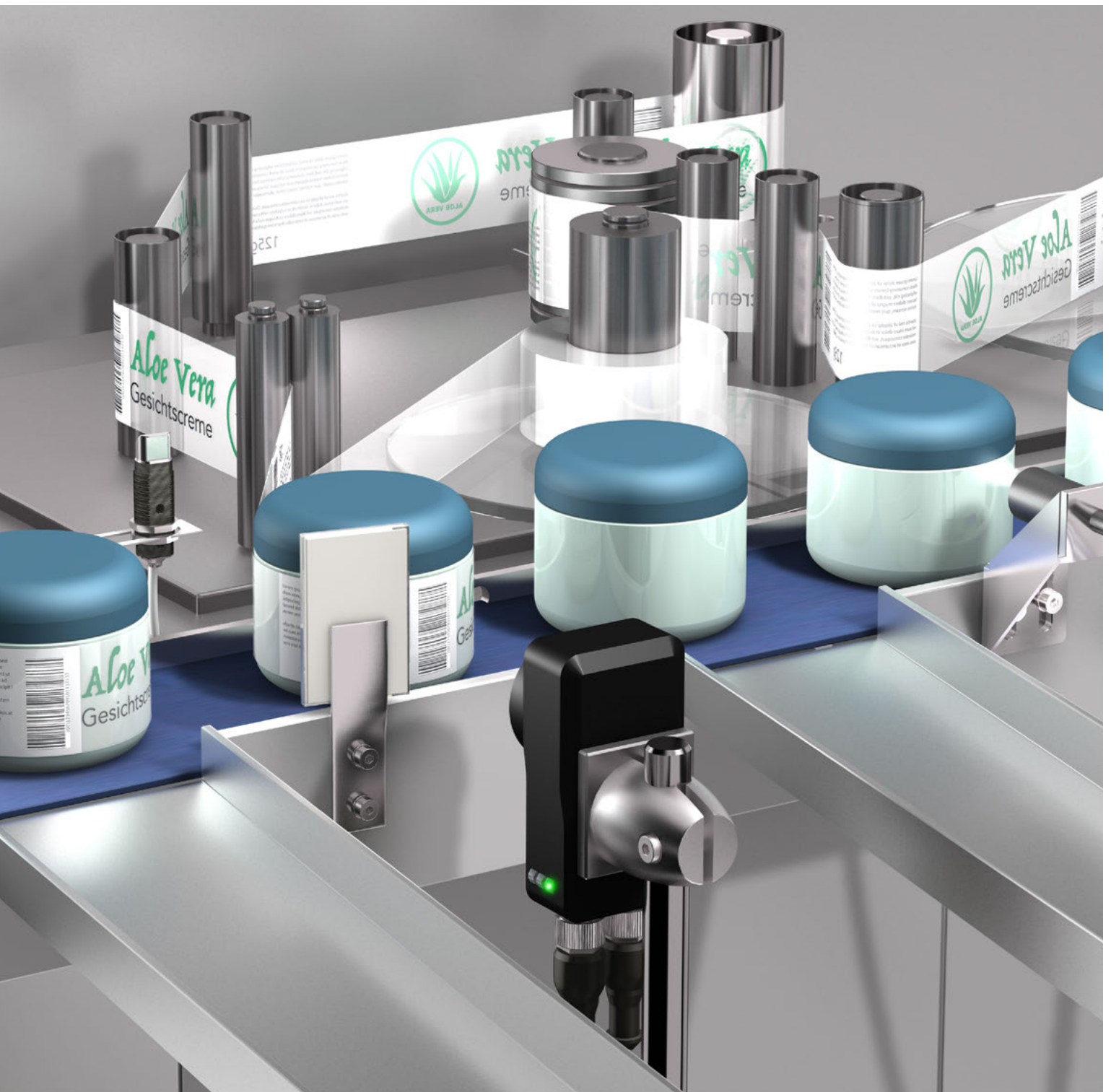

The ID reader in the rugged and compact IP67 housing is used in manufacturing companies in almost all industries. Strong algorithms ensure that all DPM codes are read, especially in the assembly & handling area. The IP67 protection class ensures that the ID-600 fixed-mounted ID reader works even in systems with high levels of dust, oil and dirt without any loss of performance.

Series in focus

ID-600 Fixed-mounted ID readers

Special features

For all conceivable ID reader applications, from reading simple barcodes to detecting difficult-to-read DPM codes, including image transfer for quality assurance



VISION SENSORS

When reconceptualizing or rebuilding systems, functional aspects and the efficient, space-saving linking of individual production and assembly units are front and foremost. Image processing systems do not come under consideration until it is clear where and to what extent measures have to be taken for process and quality control. The transport, handling and assembly applications are largely set at this stage, and vision sensors have to adjust to the pre-specified framework conditions.

For demanding object detection tasks, for example in connection with high process speeds, large distances to the object or the effect of ambient light, simple vision sensors with a liquid lens and autofocus tend to reach their limits. With the CS-60 Vision sensor, di-soric has developed a novel sensor type for demanding inspection tasks that is unique on the market with respect to the flexibility offered, intuitive operation and the price-performance ratio.

The flexible Vision sensor can be configured on demand and is suited for various handling, assembly and testing tasks in all industries. With exchangeable M12 lenses and integrated LED high-performance lighting in the light colors white and red, the CS-60 Vision sensor offers image results of the highest quality.

Even the base version of the CS-60 has a large toolkit, with the tool sets Detection, Localization, and Counting, by means of which the numerous testing tasks can be solved.

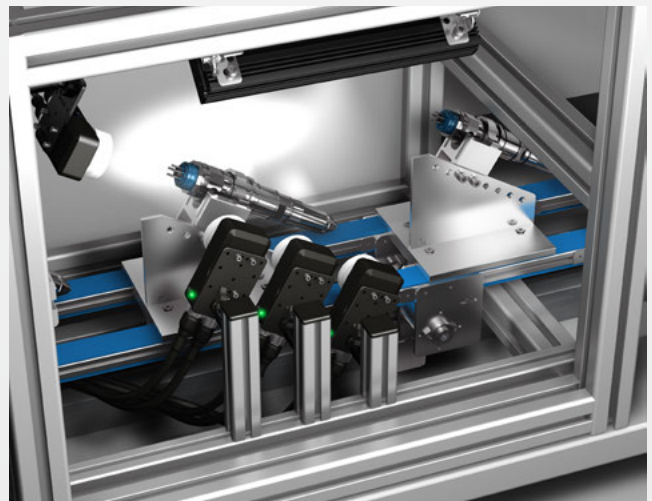
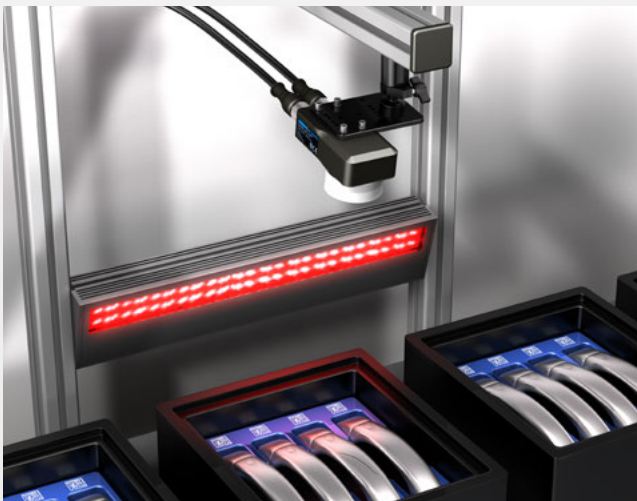

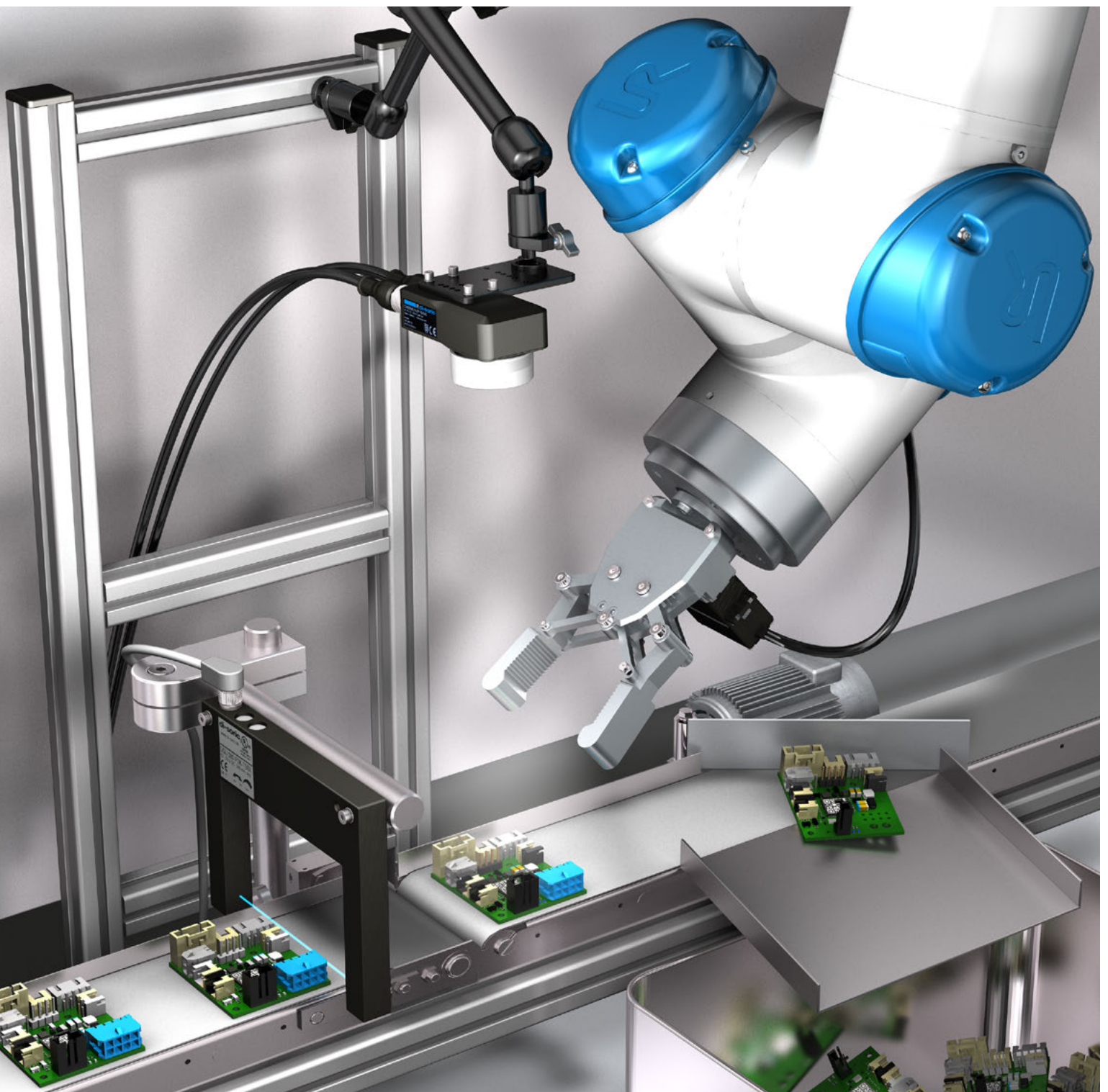

Through software, tools can be loaded as needed, such as “Measure” or “Detect and read 1D/2D codes”, and make the base version a multifunctional vision system that is precisely customized to existing requirements. An upgrade takes just a few minutes, and users only pay for what they need. In the future, sensors will no longer need to be replaced due to changing application requirements.

As desired, the look & feel of the user interface can be adapted to the corporate design of the user's company. Regular updates which keep the devices current are made available by di-soric free of cost.

Series in focus

CS-60 Vision sensors

Special features

For all conceivable vision sensor applications, from simple presence checking to quality inspections and measurements to coordinate transfer in real millimeter values – including image transfer for quality assurance

nVISION-i

The image processing software of our CS-60 Vision sensors and the ID-600 fixed-mounted ID readers

Our easy-to-operate configuration software, which enables an extremely quick and effective solution of the application requirements with CS-60 Vision sensors or ID-600 ID readers thanks to its graphic user interface.

Save time

Not just because of the interface, which is clear, intuitive and simple to operate, but also because of the high-performance tools, which can be optimized at the highest level of quality and with the highest level of performance.

The visualization of the pipeline and linking of individual tasks in the Logic tool make the greatest degree of flexibility and high speed in the realization of the application possible.

Pipeline & status checks

- Inspection tools can be inserted here and moved via drag & drop
- Measured values and check results/status are shown here

Navigation bar & inspection tools

- Intuitive and user-friendly navigation menu
- Contextual help can be displayed as needed
- Menu guidance can be toggled between 7 languages (German, English, French, Italian, Spanish, Chinese, and Korean)

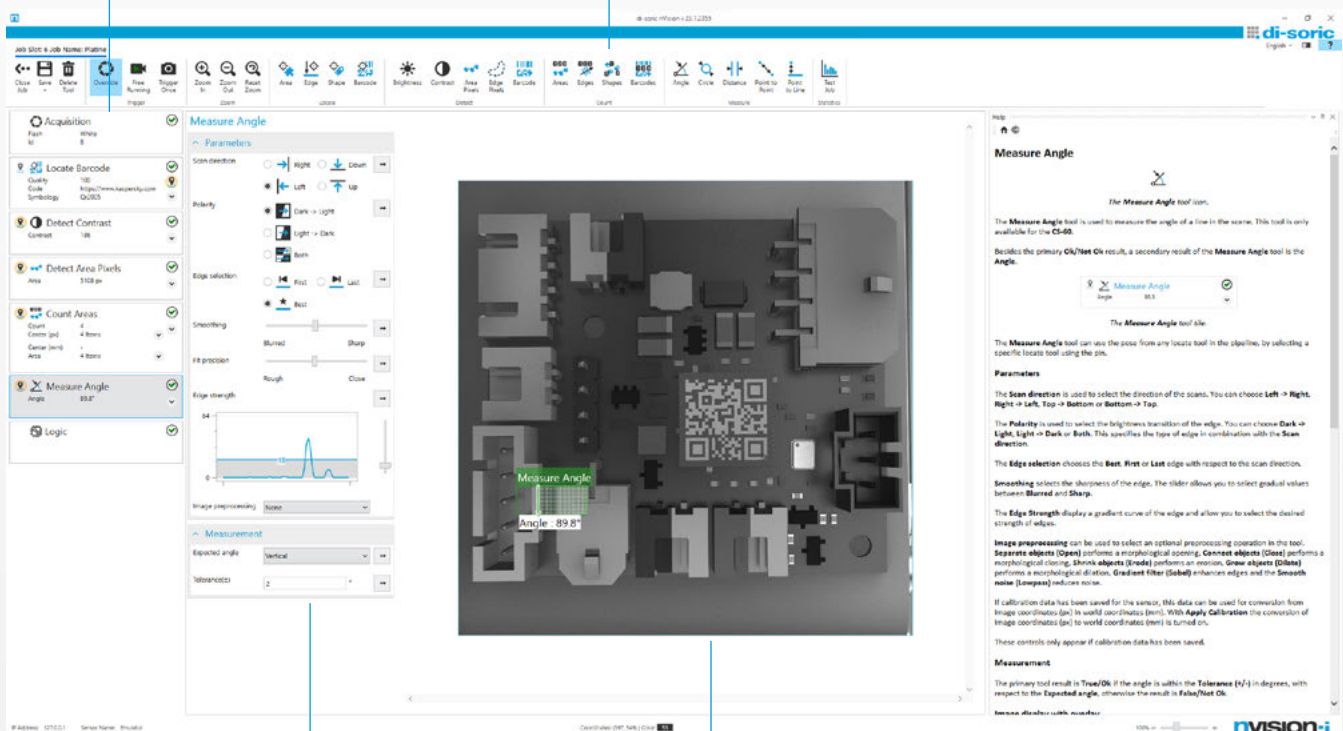

Configuration

- Parameters for search criteria can be set simply and directly
- Threshold values for the evaluation criteria can be entered easily

Display & drawing tools

- Image viewing for control and analysis during operation
- Context-sensitive description of the tools on the right side to ensure optimal tool use with their complete functionality

Upgrades – Only pay for what you need

nVision is not just intuitive and easy to operate but you can also individually adapt it to your application requirements and expand it through upgrades and customization. Consequently, CS-60 Vision sensors and ID-600 ID readers are always equipped with the functions that are necessary to solve your applications.

High performance and versatility

The versatility to link various tool results enables the Vision sensors and ID readers to process various types without switching between jobs – for example, when the production process runs with multiple varieties.

The great versatility is another advantage:

Profinet communication can be adapted to existing standard communication modules.

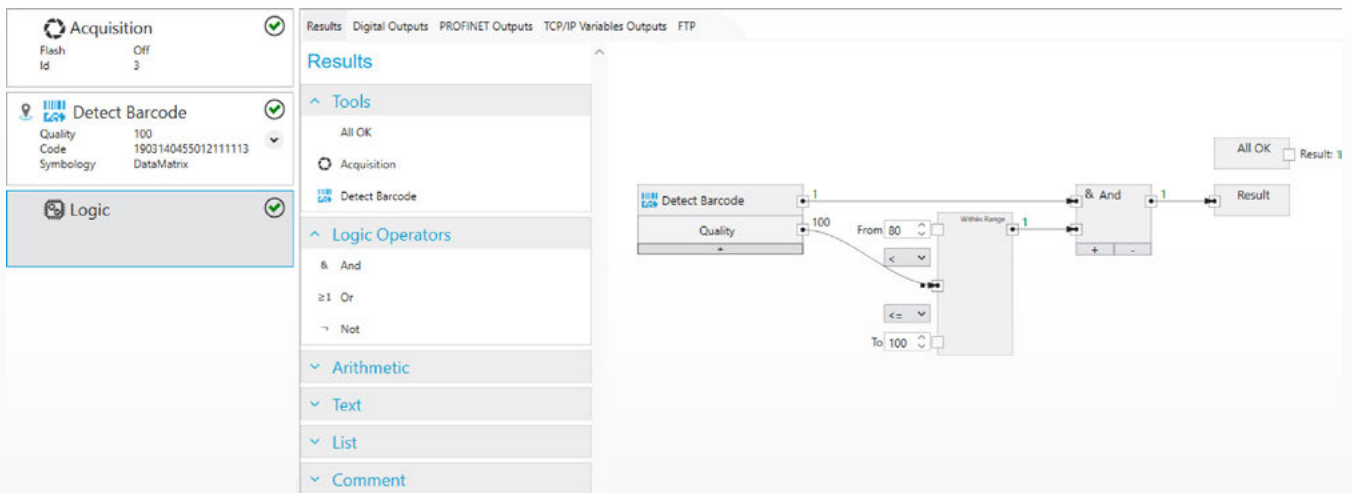

Short orientation period, no training required

The graphically oriented Logic tool is based on a function plan (FUP), whereby a clear display is possible, even in more complex functions. This, in turn, ensures that the implementation of the behavior of inputs and outputs is simple and highly transparent. This eliminates the need for training, since the procedure is already familiar from daily use of PLC programming.

Integrated image optimization



With two clicks, distortions and shadowing at the image edge can be easily eliminated through calibration using nVision-i.

The CS-60 Vision sensors and ID-600 ID readers therefore have the ability to safely execute detections across the entire field of view – the CS-60s can also convert pixel values into exact, real values (mm) and output them.



nVision-i and upgrades for CS-60 vision sensors and ID-600 ID readers



LIGHTING FOR INDUSTRIAL IMAGE PROCESSING

di-soric lighting is the perfect choice for better image results in applications due to the support of image-capturing Vision sensors, smart cameras, and ID Readers. They emphasize object features or properties in various image-processing applications with various lighting scenarios. Our extensive product ranges comprises area, bar, spot, ring, coaxial, dark field, and dome lighting. To satisfy application requirements, lighting is available not only in all common light colors, but the lighting also distinguishes itself through its high IP protection class and flexibility due to load-free trigger and trigger inversion functions.

Series in focus

Special features

BE-F Area lights	For background illumination and contour inspection
BE-B Barlights	For homogeneous incident lighting, for surface and silhouette detection
BE-P Spotlights	For targeted illumination of objects for examination and surface and silhouette detection, perfect for confined spaces
BE-R Ringlights	For shadow-free illumination for surface and silhouette detection
BE-K Coaxial lights	For shadow-free, axial illumination and suppression of surface reflections
BBE-D Darkfield lights	For contrast enhancement in case of surface defects
BE-DOME Dome lights	For suppression of shadows due to ragged or scratched surfaces

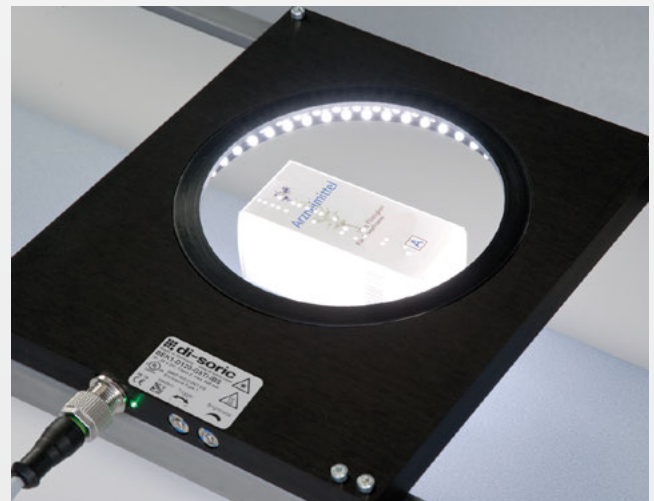
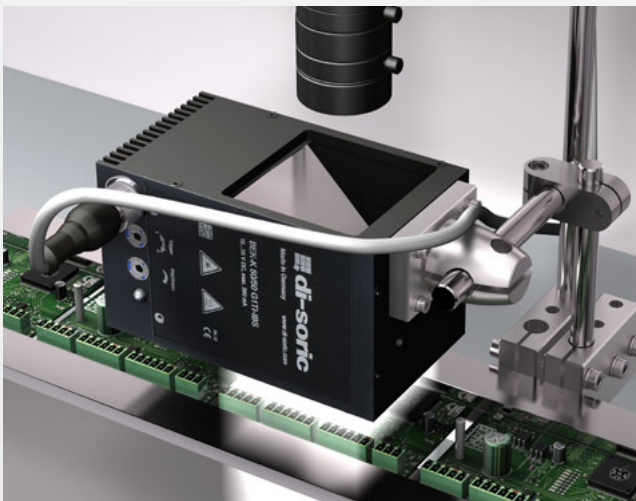



LENSES C AND S MOUNT

The selection of the correct lens is of decisive importance for the quality of your created image. It influences important parameters such as measurement precision, freedom from errors and distortion, which in turn crucially affects the reliability of your subsequent evaluation. Our di-soric lenses are available in various designs and distinguish themselves through their first-class optical quality as well as their extremely robust construction.

The lenses in the O-C series are standard lenses with a fixed focal length and represent a good value for the money. With various models with different focal lengths, this series is suited for many applications in industrial image processing. A filter thread comes standard in all models. The lenses are distinguished by low optical distortion.

O-S lenses with S mount for CS-60 Vision sensors and ID-600 ID readers are available with various focal lengths and apertures and impress with their very robust mechanical design and highest optical quality.

Series in focus

Lenses with C mount O-C

Special features

Suited for devices with C mount port and many applications in industrial image processing

Lenses with S mount O-S

Suited for many applications with CS-60 Vision sensors and ID-600 ID readers in industrial image processing

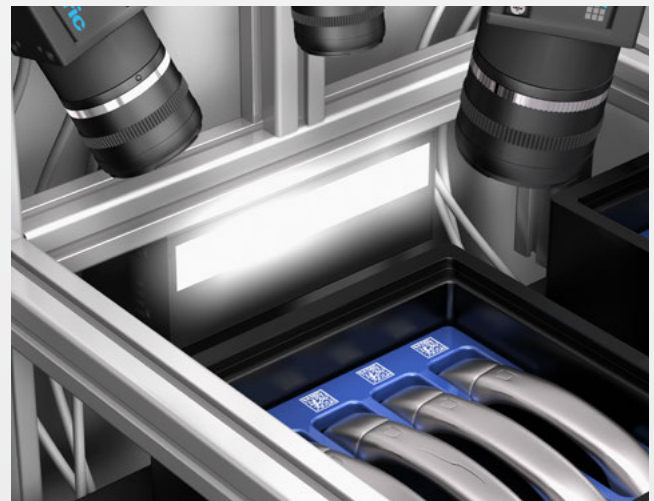
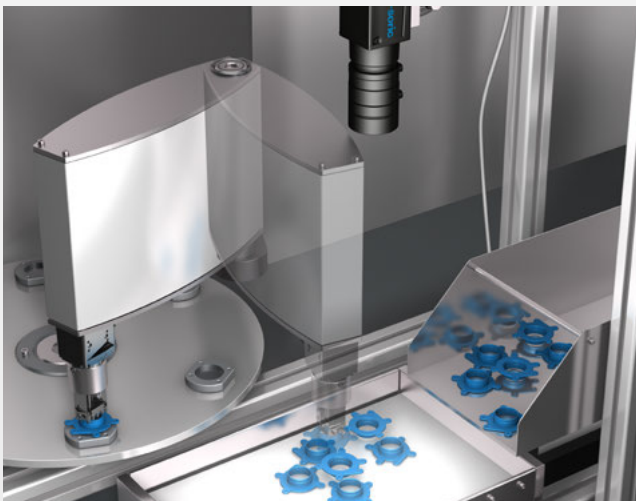



MACHINE LIGHTING

The robust, industrial-suited lights from di-soric make the illumination of machines possible in the highest light quality and are distinguished by their compact design and load-free triggers that meet the strictest requirements. We have high-illumination and reliable lighting solutions for use in simpler industrial environments and also for harsh environments with high requirements for resistance in our product range.

For individual machines and systems, there is a large selection of lengths available, which enable ambitious designs.

Series in focus

Special features

MB-R Semicircular	For use in machines or harsh production environments
MB-N Flat	Designed for universal use, compact, highest light quality
MB-NP Protected	For use under harsh production conditions, maximum robustness
MB-RGBW with status indicator	Designed for universal use, compact, with additional signal element

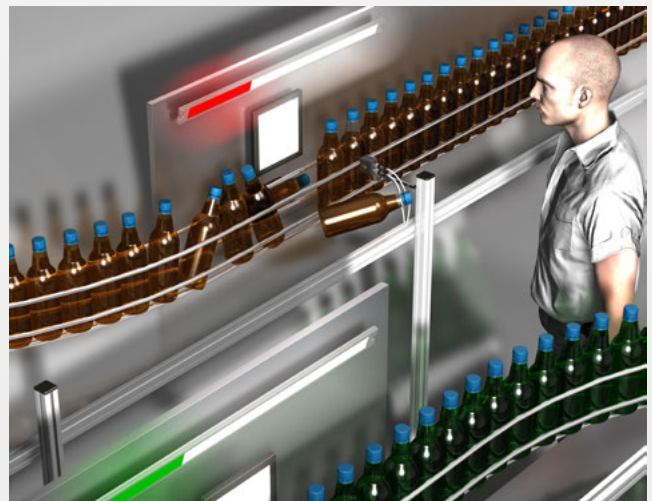

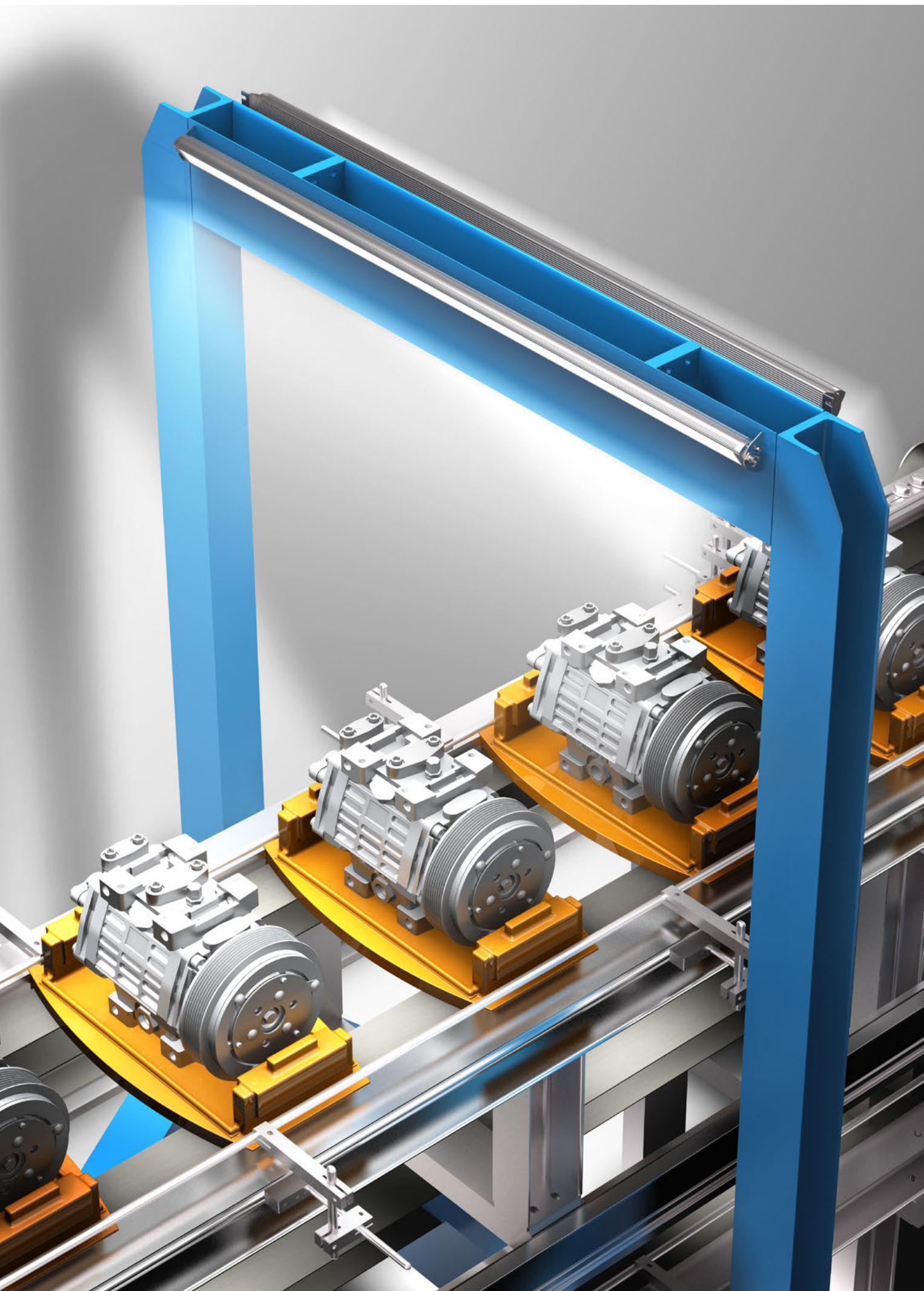



SIGNAL LIGHTING

Signal lighting from di-soric is the ideal solution for optical visualization of production progress and states of machines and systems – also clearly visible at long distances and in the highest color brilliance. With its outstanding flexibility through IO-Link, color, brightness and flashing behavior can be adjusted according to your requirements.

Series in focus

SB-RGB Signal lighting

Special features

For optical visualization of progress or states in production, status display of machines or systems, very flexible, color, brightness and flashing behavior can be freely configured

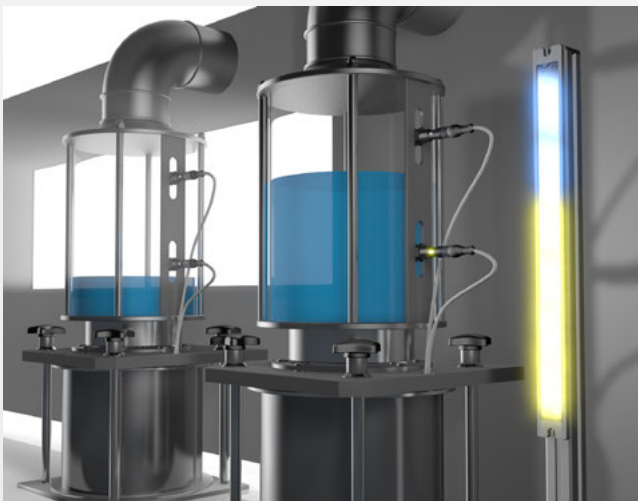





SIGNAL LIGHTS

di-soric signal lights with 360° visibility are perfectly suited for industrial display applications. These robust signal lights enable a wide range of color selections and signal display options depending on the task at hand. They impress with the brightness of their signals even in challenging production environments and optionally offer the option of acoustic signaling in the signal columns in order to additionally ensure that signals are noticed.

Series in focus	Special features
SBT-F Fixed color signal columns	For standard applications with fixed color coding per segment
SBT-RGB Signal columns	For ambitious applications, in which colors, flashing behavior and brightness per segment can be adjusted, multi-segment, IO-Link
SBP-RGB Signal lights	For applications that do not require multi-step visual signals, colors, flashing behavior and brightness are individually adjustable, 1-segment, IO-Link

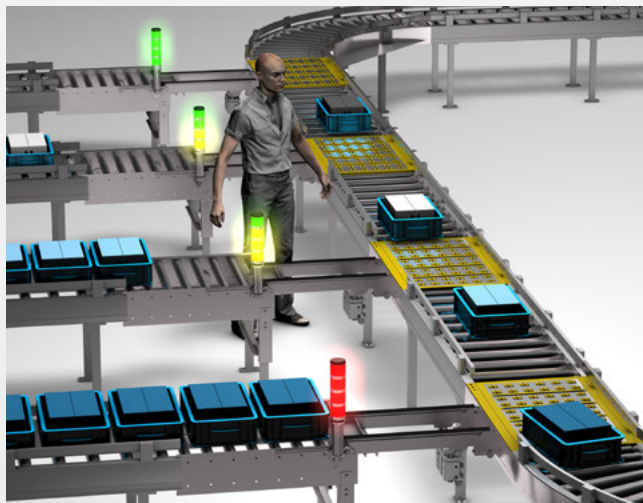



UNIVERSAL ACCESSORIES

Connection technology

In the area of connection technology, a wide variety of electrical contacts for customized industrial installation are available.



Signal preparation

Logic distributors can link two sensors with one another (e.g. AND/OR function). Function adapters change switching signals (e.g. npn, pnp, inversion, pulse stretching), counter modules count switching signals.



Universal mounting technology

di-soric offers tailored bracket and fastening systems for all of its sensors, image processing systems, identification systems and lighting.



Configuration and testing devices

Configuration and testing devices facilitate function tests of sensors. IOL Master and IOL Portable enable the display of measured values as well as the diagnoses and the configuration of IO-Link-capable sensors without additional control. The sensor tester is suited for pnp and npn sensors.



IOL-Master
Operation on PC via USB



IOL Portable
handheld operation without PC



Sensor tester
ST 7PNG

PRODUCT-SPECIFIC ACCESSORIES

Sensor accessories

The wide range of di-soric accessories offers the optimum solution for embedding and commissioning common sensors into machines and systems.



Accessories for image processing & identification

We offer a comprehensive assortment of accessories for our products in the area of image processing. From brackets for our lights to cables.



Accessories for machine lighting & signal lights

di-soric offers optimal accessories, such as dimmers, assembly accessories, power supplies, and diffusers for the machine and signal lighting portfolio.



You want something else?

You would like to be consulted on our products and solutions or have questions on commercial or technical issues or would like to request informational material, such as product brochures?

Customer Service

+49 7181 9879 - 710
customer-service@di-soric.com

Monday - Friday
during normal business hours

Technical Customer Service

+49 7181 9879 - 700
service@di-soric.com

Monday - Friday
during normal business hours

Sales

+49 7181 9879 - 710
sales@di-soric.com

Monday - Friday
during normal business hours

Order samples



SOLUTIONS. CLEVER. PRACTICAL.

di-soric Headquarters

Germany: di-soric GmbH & Co. KG | Steinbeisstrasse 6 | 73660 Urbach
Phone +49 71 81 98 79-0 | Fax +49 71 81 98 79-179 | info@di-soric.com

di-soric Subsidiaries

Austria: di-soric GmbH & Co. KG | Phone +43 7228 72 366 | info.at@di-soric.com

China: di-soric Industrial Automation (Suzhou) Co. Ltd. | Phone +86 199 5127 5458 | info@di-soric.cn

France: di-soric SAS | Phone +33 476 61 65 90 | info.fr@di-soric.com

Singapore: di-soric Pte. Ltd. | Phone +65 6694 7866 | info.sg@di-soric.com

For further information visit www.di-soric.com/international

www.di-soric.com