

# KNS M12KM 8N G3-2R

Kapazitiver Näherungsschalter  
 Capacitive proximity switch  
 Détecteur de proximité capacitif

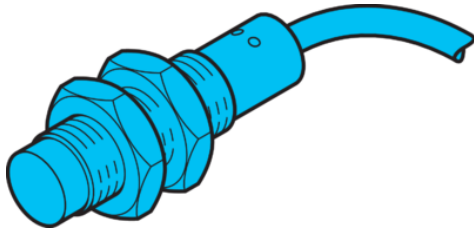

di-soric GmbH & Co. KG  
 Steinbeisstraße 6  
 DE-73660 Urbach  
 Germany  
 Tel: +49 (0) 7181/9879-0  
 info@di-soric.com · www.di-soric.com

212682



Stand 16.07.24, Änderungen vorbehalten  
 As of 07/16/24, subject to change  
 État 16.07.24, sous réserve de modifications

Funktion / Function / Fonction

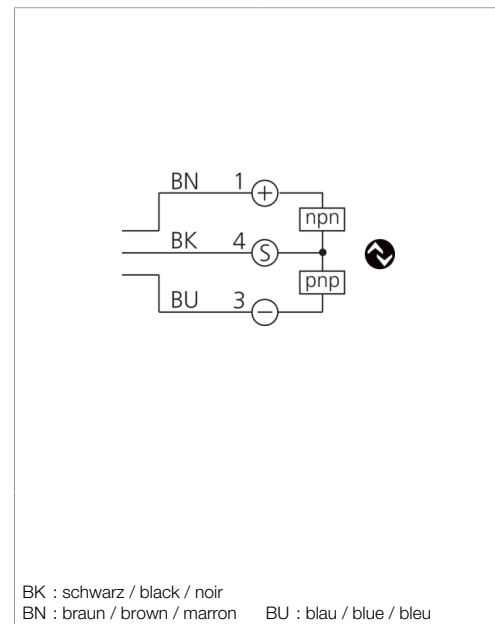
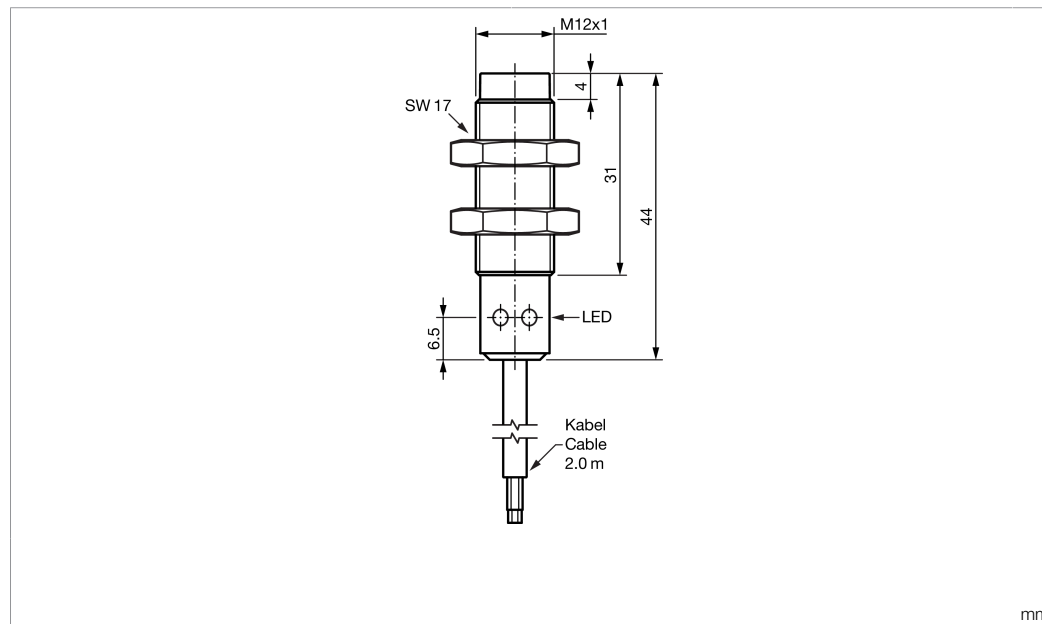

Technische Daten	Technical data	Caractéristiques techniques	+20°C, 24 V DC
Funktionsprinzip	Operating principle	Principe de fonctionnement	Kapazitiv / Capacitive / Capacitif
Einbauart	Installation type	Type de montage	nicht bündig / non-flush / Non affleurant
Schaltabstand	Switching distance	Distance de commutation	8 mm
Betriebsspannung	Service voltage	Tension de service	18 ... 30 V DC
Schaltausgang	Switching output	Sortie de commutation	Gegentakt, 100 mA, NO/NC, umschaltbar per IO-Link / Push-pull, 100 mA, NO/NC, switchable via IO-Link / Push-pull, 100 mA, NO/NC, Commutable via IO-Link
Leerlaufstrom (max.)	No-load current (max.)	Courant de marche à vide (max.)	15 mA (24 V DC)
Schutzart	Protection type	Indice de protection	IP 65, IP 67
Umgebungstemperatur Betrieb	Ambient temperature during operation	Température ambiante de fonctionnement	-20 ... +70 °C

Sicherheitshinweise	Safety instructions	Consignes de sécurité
<b>Allgemeiner Sicherheitshinweis</b> WARNUNG! Kein Sicherheitsbauteil gemäß 2006/42/EG und EN 61496-1/-2! Darf nicht zum Personenschutz eingesetzt werden! Nichtbeachtung kann zu Tod oder schwersten Verletzungen führen! Nur bestimmungsgemäß verwenden!	<b>General safety notice</b> WARNING! Not a safety component pursuant to 2006/42/EG and EN 61496-1/-2! May not be used for personal protection! Non-compliance can lead to death or serious injuries! Only use as directed!	<b>Consigne de sécurité générale</b> AVERTISSEMENT ! Ce produit n'est pas un composant de sécurité au sens des réglementations 2006/42/CE et NF EN 61496-1/-2 ! Ne pas l'utiliser pour la protection des personnes ! Le non-respect de cette consigne peut entraîner la mort ou des blessures graves ! N'utiliser le produit que selon son utilisation conforme !

# di-soric

## KNS M12KM 8N G3-2R

电容式接近开关

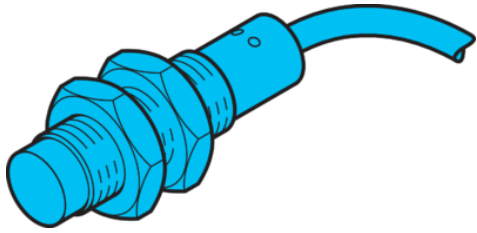

di-soric GmbH & Co. KG  
Steinbeisstraße 6  
DE-73660 Urbach  
Germany  
Tel: +49 (0) 7181/9879-0  
info@di-soric.com · www.di-soric.com

212682



版本 24.07.16, 保留变更权

功能

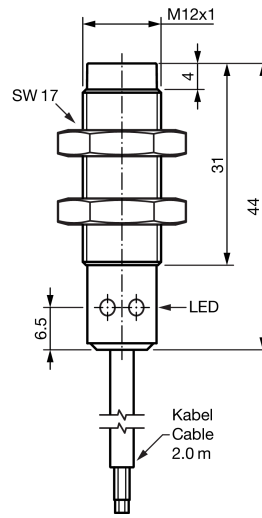

mm

BK : 黑色  
BN : 棕色

BU : 蓝色

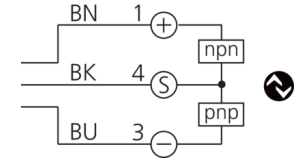

### 技术数据

工作原理

内装方式

感应距离

工作电压

开关输出端

空载电流 (最大)

防护等级

工作环境温度

+20°C, 24 V DC

电容式

非齐平

8 mm

18 ... 30 V DC

推挽式, 100 mA, NO/NC, 可通过 IO-Link 切换

15 mA (24 V DC)

IP 65, IP 67

-20 ... +70 °C

### 安全提示



#### 一般安全提示

警告！没有符合 2006/42/EU 和 EN 61496-1 /-2 标准的安全结构件！不得用于人身安全保护！不遵守规定会导致死亡或重伤危险！仅按规定使用！