

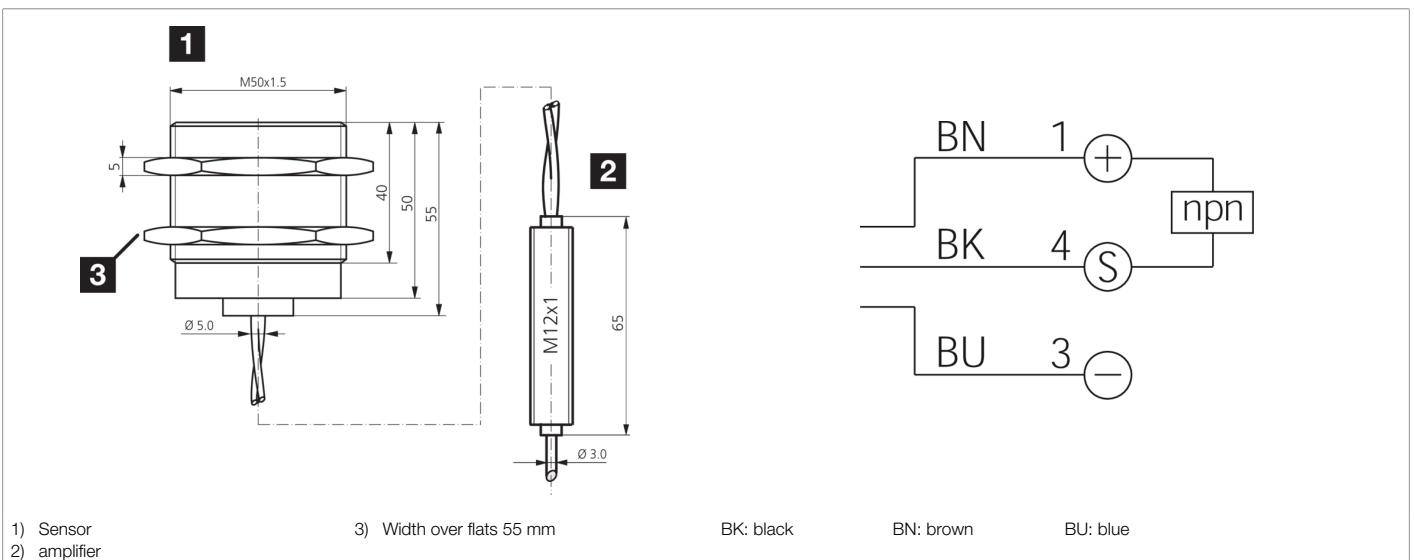

205413
DCC 50 VH 20 NSK/230/V
Inductive proximity sensor

- High-temperature resistant up to 230 °C permanent temperature
- Stainless steel housing
- Sensing surface LCP
- Cable material PTFE
- External amplifier
- Short-circuit protection
- Starting pulse suppression



Function											

Technical data (typ.)	+20°C, 24 V DC
Service voltage	10 ... 30 V DC
Internal power consumption	5 mA
Insulation voltage endurance	500 V
Installation type	quasi-flush
Thread	M50 x 1.5
Housing length	50 mm
Housing material	Stainless steel (LCP)
Material of cable	PTFE
Tightening torque	100 Nm
Protection class	III, operation on protective low voltage
Operating principle	inductive
Evaluation	digital
Design	Thread
Characteristics	< +230 °C, high-temperature resistant
Product series	INH High-temperature resistant
Switching output	npn, 200 mA, NO
Voltage drop (max.)	2 V
Switching distance (SN)	20 mm
Standardized measuring plate	60 x 60 x 1 mm



205413

DCC 50 VH 20 NSK/230/V

Inductive proximity sensor

Technical data (typ.)	+20°C, 24 V DC
Switching hysteresis (max.)	3 ... 15 %
Switching frequency	150 Hz
Ambient temperature during operation	0 ... +230 °C (Sensor)
Protection type	IP 65
Connection	Cable, 3.0 m (flying leads)
Connection 2	Cable (2 m, amplifier / IT)
More information / accessories	https://www.di-soric.com/205413