

206198
DCCQ 08 M 03 PSLK/5m PUR
Inductive proximity sensor

- Highly flexible cable
- Integrated amplifier
- Short-circuit protection
- Starting pulse suppression
- LED

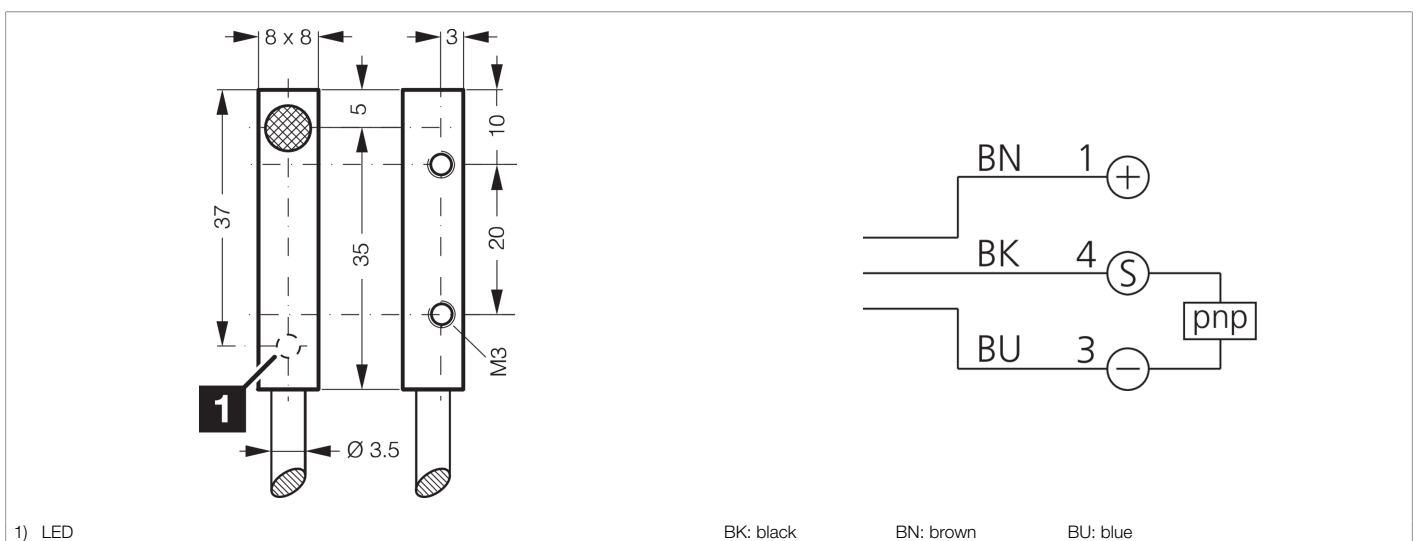

Function											
											 

Technical data (typ.)	+20°C, 24 V DC
Service voltage	10 ... 30 V DC
Internal power consumption	< 10 mA
Insulation voltage endurance	According to IEC 60947-5-2 (7.2.3.1)
Installation type	quasi-flush
Housing dimensions	8 x 8 mm
Housing length	40 mm
Housing height	8 mm
Housing width	8 mm
Housing material	Zamak (chromium-plated)
Material of cable	Polyurethane
Protection class	III, operation on protective low voltage
Operating principle	inductive
Evaluation	digital
Design	Cuboid design
Characteristics	extremely high operating distance
Product series	INE Extended
Switching output	pnp, 200 mA, NO
Voltage drop (max.)	2 V (200 mA)
Switching distance (SN)	3 mm
Standardized measuring plate	9 x 9 x 1 mm



206198

DCCQ 08 M 03 PSLK/5m PUR

Inductive proximity sensor

Technical data (typ.)

+20°C, 24 V DC

Switching hysteresis (max.)

< 10 %

Switching frequency

1000 Hz

Ambient temperature during operation

-25 ... +70 °C

Protection type

IP 67

Connection

Cable, 5.0 m (flying leads)

More information / accessories

<https://www.di-soric.com/206198>