

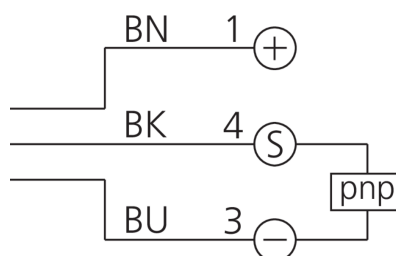

**210394**  
**DCC 05 V 1.5 PSLK/5m**  
**Inductive proximity sensor**

- Stainless steel housing
- Highly flexible cable
- Integrated amplifier
- Short-circuit protection
- Starting pulse suppression
- LED

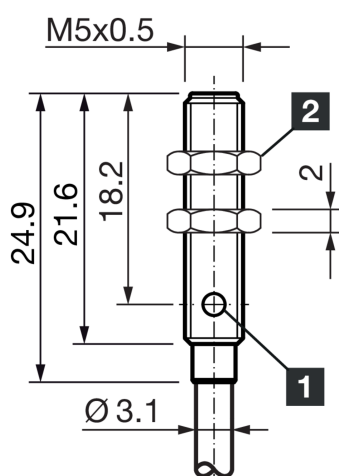

1) LED

2) Width over flats 7 mm

BK: black

BN: brown

BU: blue

**Function**

																				CE	
--	--	--	--	--	--	--	--	--	--	--	--	--	--	--	--	--	--	--	--	----	--

Technical data (typ.)	+20°C, 24 V DC
Service voltage	10 ... 30 V DC
Internal power consumption	< 10 mA
Insulation voltage endurance	500 V
Installation type	Flush
Thread	M5 x 0.5
Housing length	24.9 mm
Housing material	Stainless steel (AISI303)
Material of cable	PVC
Material of sensor probe	PBT
Protection class	III, operation on protective low voltage
Operating principle	inductive
Evaluation	digital
Design	Thread
Characteristics	increased operating distance
Product series	INM-300 Miniature Extended
Switching output	pnp, 100 mA, NO
Voltage drop (max.)	1.5 V (100 mA)
Switching distance (SN)	1.5 mm
Standardized measuring plate	4 x 4 x 1 mm
Switching hysteresis (max.)	1 ... 20 %



**210394**  
**DCC 05 V 1.5 PSLK/5m**  
**Inductive proximity sensor**

<b>Technical data (typ.)</b>	<b>+20°C, 24 V DC</b>
LED Anzeige	Yes
Switching frequency	5000 Hz
Ambient temperature during operation	-25 ... +70 °C
Protection type	IP 67
Connection	Cable, 5.0 m (flying leads)
<b>More information / accessories</b>	<b><a href="https://www.di-soric.com/210394">https://www.di-soric.com/210394</a></b>