

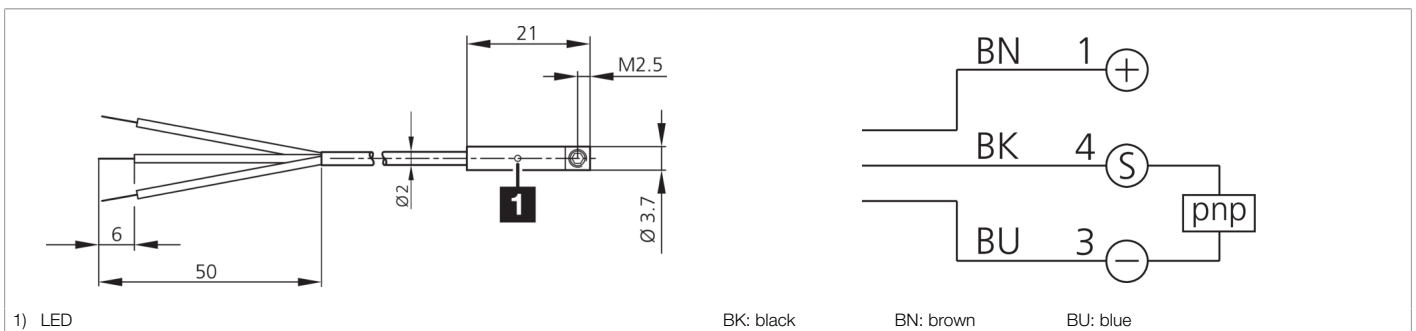



210597
MZEC3.7VPS-3/5M
Cylinder sensor

- For pneumatic cylinders with round groove 3.7 mm
- Short design
- Mounting element made of stainless steel
- Highly flexible cable
- Fully electronic
- High reproducibility
- High protection type



Function												
												 

Technical data (typ.)	+20°C, 24 V DC
Current-carrying capacity	100 mA, not short-circuit-proof, polarity-safe
Service voltage	10 ... 30 V DC
No-load current (max.)	12 mA
Insulation voltage endurance	500 V
Cylinder groove	C-groove 3.7 mm, insertion in lateral direction of groove
Mounting	Locking screw (Allen screw SW 1.3 mm)
Housing material	Stainless steel (V2A 1.4305 / AISI 303)
Material of cable	TPU
Protection class	III, operation on protective low voltage
Switching output	pnp, 100 mA, NO
Voltage drop (max.)	2 V
Switching capacity	< 3 W (30 V, 100 mA)
Reproducibility	< 0.1 mm
Display	LED yellow - Output signal
Switching frequency	1000 Hz
Ambient temperature during operation	-20 ... +70 °C
Protection type	IP 67
Connection	Cable, 5.0 m, 3-pin, 3 x 0.08 mm ²

More information / accessories	https://www.di-soric.com/210597
--------------------------------	---