

BEK-A-MOUNTINGSET

Montageset
Mounting set
Kit de montage

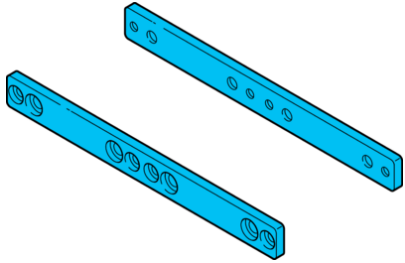

di-soric GmbH & Co. KG
Steinbeisstraße 6
DE-73660 Urbach
Germany
Tel: +49 (0) 7181/9879-0
info@di-soric.com · www.di-soric.com

208187

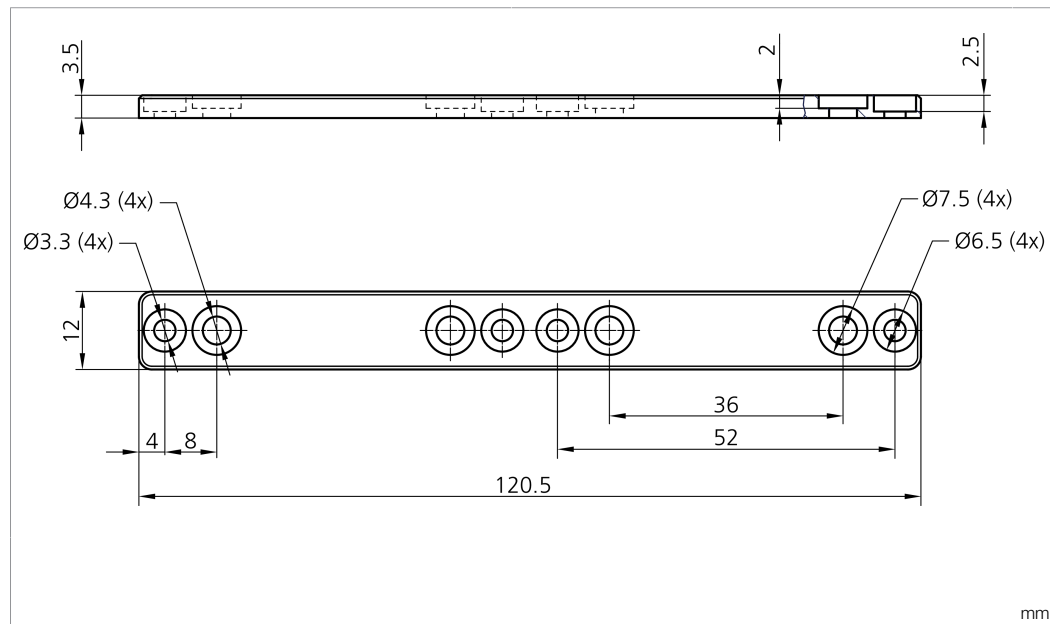

Technische Daten	Technical data	Caractéristiques techniques	
Geeignet für	To be used for	Convient pour	Aufflichtbeleuchtungen BE-A100..., Aufflichtbeleuchtungen BE-A300... / Barlights BE-A100..., Barlights BE-A300... / Barres d'éclairage BE-A100..., Barres d'éclairage BE-A300...
Größe	Size	Dimensions	12 x 120,5 x 3,5 mm / 12 x 120.5 x 3.5 mm / 12 x 120,5 x 3,5 mm
Material	Material	Matériau	Aluminium, schwarz (eloxiert) / Aluminum, Black (Anodized) / Aluminium, Noir (Anodisé)
Lieferumfang	Scope of delivery	Contenu de la livraison	Set besteht aus zwei Stück / Set consists of two pieces / Kit comprenant deux pièces

Stand 16.07.24, Änderungen vorbehalten

As of 07/16/24, subject to change

État 16.07.24, sous réserve de modifications

BEK-A-MOUNTINGSET

装配套装

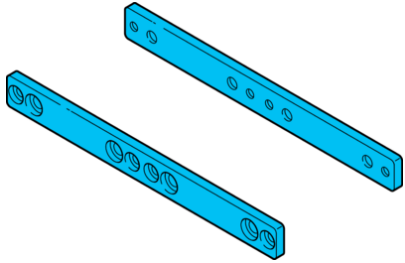

di-soric GmbH & Co. KG
 Steinbeisstraße 6
 DE-73660 Urbach
 Germany
 Tel: +49 (0) 7181/9879-0
 info@di-soric.com · www.di-soric.com

208187

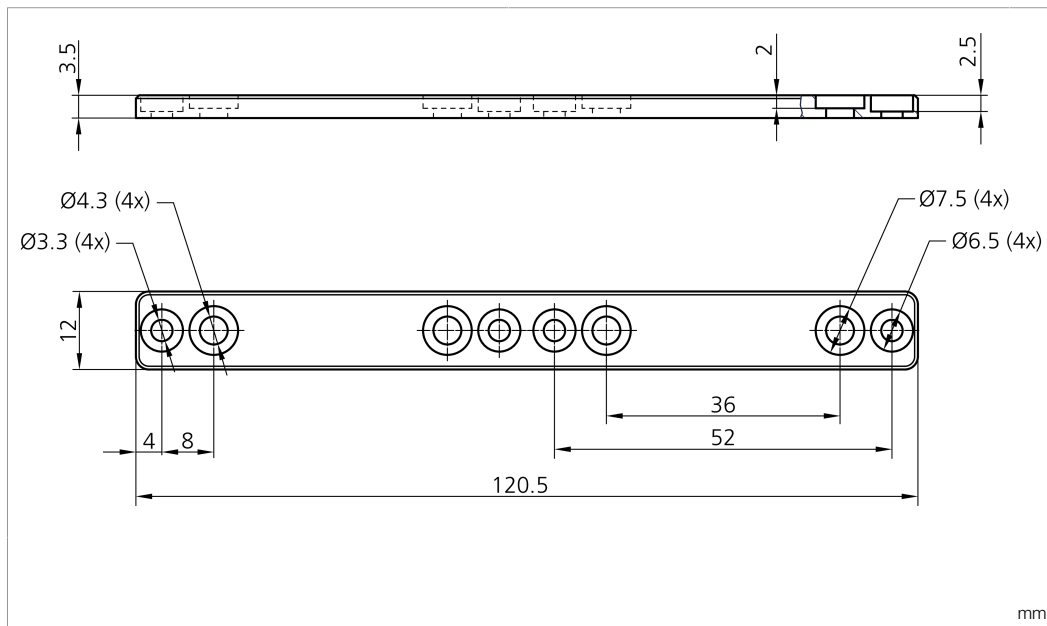

技术数据

适用于

条形光源 BE-A100..., 条形光源 BE-A300...

尺寸

12 x 120.5 x 3.5 mm

材料

铝, 黑色 (阳极氧化)

供货范围

两件套

版本 24.07.16, 保留变更权

Flächenbeleuchtung

Aufgrund des technisch bedingt erhöhten Einschaltstroms empfehlen wir eine geeignete Stromversorgung, die kurzzeitig mindestens 5A liefern kann.



Nicht dauerhaft in den Lichtstrahl blicken!



Diese Beleuchtung erzeugt eine sichtbare oder unsichtbare Strahlung, welche bei dauerhafter Einwirkung schädlich sein kann!



Wärme Konvektion gewährleisten!

Die Erwärmung der Beleuchtung hat einen direkten Einfluss auf die Alterung/Lebensdauer der Beleuchtungs-LEDs! Je höher die Temperatur, desto stärker die Alterung.



- Beleuchtung nicht abdecken

- Beleuchtungsintensität an die Applikation anpassen (überschüssige Lichtstärke vermeiden)

- Dauerlicht reduzieren/vermeiden (Triggerfunktion nutzen)

- Beleuchtung bei längerer Nichtnutzung abschalten



Betriebswärme folgendermaßen abführen:

- Montage an eine kühlende Fläche (Maschinenkörper)

- Montage an einen externen Kühlkörper



Regelmäßige Reinigung!

Starke Verschmutzung verhindert den Lichtaustritt und erhöht die Wärmeentwicklung.

Back light

Due to technical reasons increased inrush current we recommend a suitable power supply delivering a short-term capacity of 5A.



Do not look into the light beam for a prolonged period of time!



This light produces radiation which may or may not be visible and prolonged exposure may be harmful!



Ensure heat convection!

The heating of the light has a direct impact on the ageing/lifetime of the light LEDs! The higher the temperature, the faster the ageing process.



- Do not cover the light

- Adapt the light intensity to the application (avoid excessive light intensity)

- Reduce/avoid continuous light (use trigger function)

- Switch off light when it is not being used for longer periods of time



Dissipate operating heat as follows:

- Install on a cool surface (machine structure)

- Install on an external cooling element



Clean on a regular basis!

Heavy contamination prevents light emission and increases heat development.

Rétro-éclairage

Pour des raisons techniques dû au courant d'appel, nous recommandons l'utilisation d'une alimentation de 5A.



Ne pas regarder le rayon lumineux pendant une période de temps prolongée!



Cette lumière produit des radiations qui pourraient ou ne pourraient pas être visibles et une exposition prolongée peut être nuisible!



Protéger de l'émission de chaleur!

La chaleur émise par la lumière a un effet direct sur le vieillissement/la durée de vie des LED! Plus la température s'élève, plus rapide est le processus de vieillissement.s



- Ne pas couvrir la lumière

- Adapter l'intensité lumineuse en fonction de la nécessité de l'application (éviter l'excès d'intensité lumineuse)

- Réduire/éviter l'éclairage continu (utiliser la fonction de déclenchement)

- Éteindre l'éclairage lorsqu'il n'est pas utilisé pendant de longues périodes



Dissiper la chaleur d'émission comme suit:

- Installer sur une surface froide (structure de la machine)

- Installer sur un élément refroidissant externe



Nettoyer régulièrement

L'encrassement entrave la bonne émission de l'éclairage et accroît l'émission de chaleur.

