

# IO-LINK SIGNAL LIGHTING & SIGNAL LIGHTS

## SB-RGB, SBT-RGB & SBP-RGB

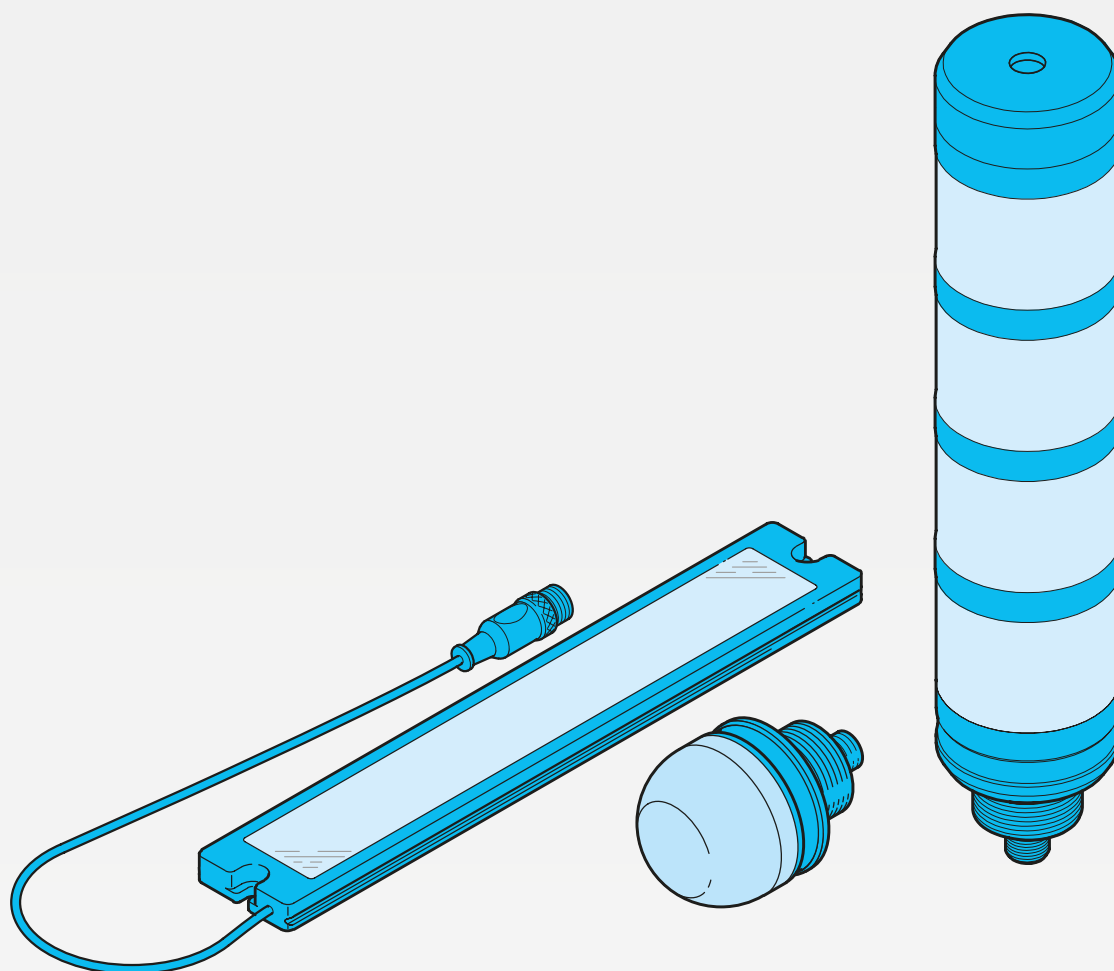

600017-0000EN · Rev 1 · 2023/01

OPERATING INSTRUCTIONS

## TABLE OF CONTENTS

<b>1 PRELIMINARY NOTE</b>	<b>3</b>
<b>2 OVERVIEW</b>	<b>4</b>
<b>3 GENERAL DESCRIPTION</b>	<b>5</b>
<b>4 NORMAL OPERATION AND APPLICATION AREAS</b>	<b>5</b>
4.1 Reliably signaling various statuses .....	5
4.2 Signal lighting: suitable for a variety of uses .....	5
4.3 Ambient conditions [IP protection classes] .....	5
<b>5 OPERATING MODES</b>	<b>6</b>
5.1 External Trigger mode.....	6
5.2 Operation via IO-Link [Segment mode, Level mode, Demo mode] .....	6
5.2.1 Communication via IO-Link.....	6
5.2.2 Segment mode .....	6
5.2.3 Level mode .....	6
5.2.4 Demo mode.....	6
<b>6 COMMISSIONING</b>	<b>7</b>
6.1 Operation without IO-Link in External Trigger mode.....	7
6.2 Operation with di-soric IO-Link master.....	7
6.3 Operation with other PLC online tools: e.g. Siemens master.....	8
<b>7 PARAMETERIZATION AND CONFIGURATION</b>	<b>9</b>
7.1 Basic functions .....	9
7.1.1 Color configuration and designation.....	9
7.1.2 Standard commands.....	10
<b>8 OPERATING MODES</b>	<b>10</b>
8.1 External Trigger mode [standard mode].....	11
8.1.1 Parameterization [parameter data].....	11
8.1.2 Application example .....	12
8.2 Segment mode .....	13
8.2.1 Parameterization [parameter data].....	13
8.2.2 Process data and application example.....	14
8.3 Level mode .....	15
8.3.1 Parameterization [parameter data].....	15
8.3.2 Process data and application example.....	16
<b>9 TROUBLESHOOTING</b>	<b>17</b>
9.1 Error display.....	17

## 1 PRELIMINARY NOTE

### Foreword | Purpose

This quick guide helps you with the initial commissioning process for di-soric SBx-RGB signal lighting and with using the USB IO-Link master to configure parameters. The quick guide is a supplementary document for the existing product documentation.

For more information, see: <http://www.di-soric.com>

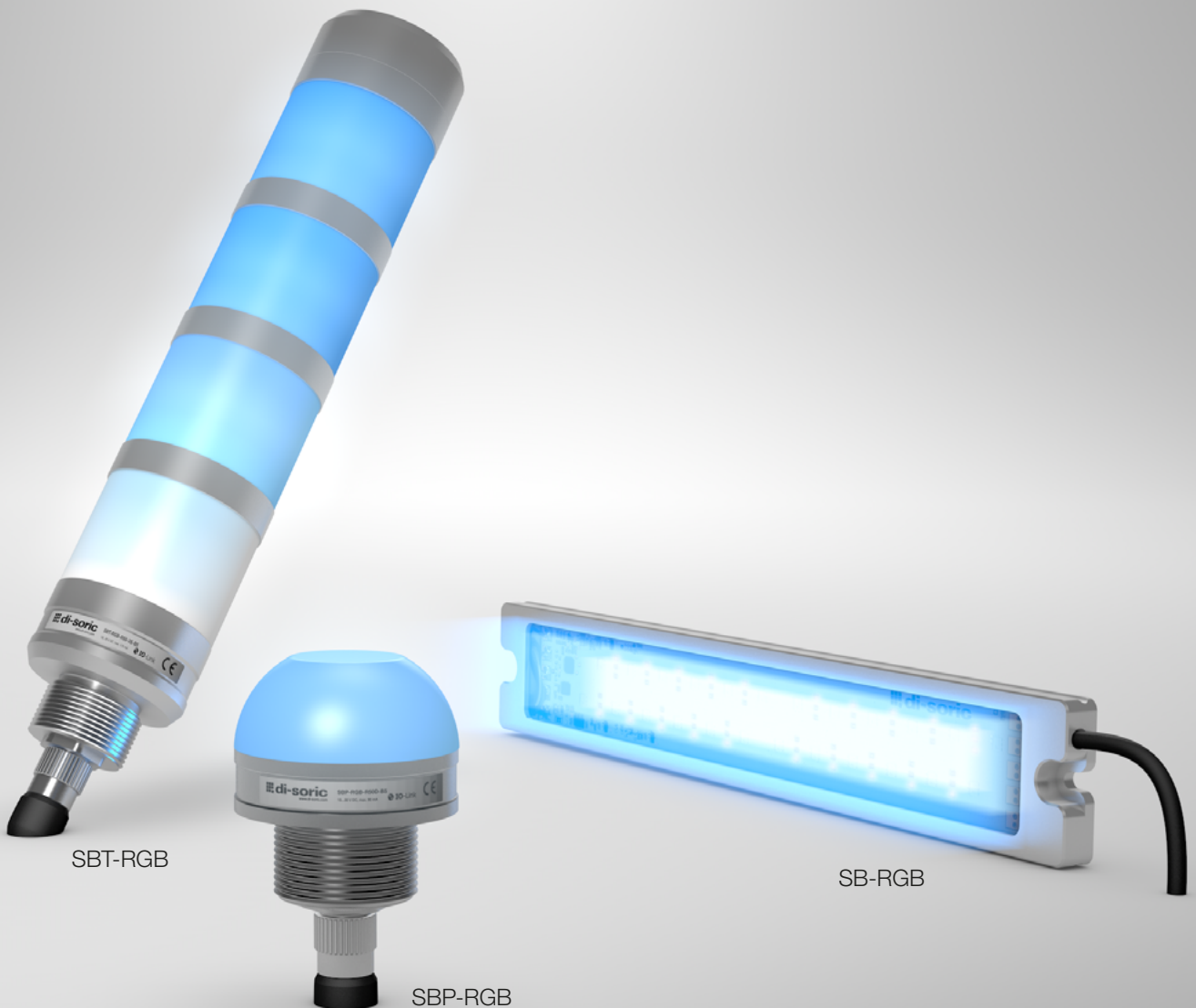

## 2 OVERVIEW

Product overview: IOL signal lighting & signal lights

<b>SBP-RGB 1-segment IOL signal lights</b>	SBP-RGB-R50D-B5
Segments	1
Operating mode	Trigger mode, Segment mode, Demo mode
Color	Red, green, yellow, blue, white, orange, pink, user-defined (IO-Link), RGB color spectrum
Brightness / intensity	10 to 100%, can be freely customized via IO-Link
Frequency / mode	Constant light, flashing light, blinking light

<b>SB-RGB multi-segment IOL signal lighting</b>	SB-RGB-126-K-B5	SB-RGB-251-K-B5	SB-RGB-481-K-B5	SB-RGB-701-K-B5	SB-RGB-911-K-B5
Segments	2	3	6	9	12
Operating mode	Trigger mode, Segment mode, Level mode, Demo mode				
Color	Red, green, yellow, blue, white, orange, pink, user-defined (IO-Link), RGB color spectrum				
Brightness / intensity	10 to 100%, can be freely customized via IO-Link				
Frequency / mode	Constant light, flashing light, blinking light				

<b>SBT-RGB multi-segment IOL signal columns with/without buzzer</b>	SBT-RGB-R50-3S-B5	SBT-RGB-R50-3B-B5	SBT-RGB-R50-4S-B5	SBT-RGB-R50-4B-B5	SBT-RGB-R50-5S-B5	SBT-RGB-R50-5B-B5
Segments	3	3	4	4	5	5
Buzzer	Without	With	Without	With	Without	With
Operating mode	Trigger mode, Segment mode, Level mode, Demo mode					
Color	Red, green, yellow, blue, white, orange, pink, user-defined (IO-Link), RGB color spectrum					
Brightness / intensity	10 to 100%, can be freely customized via IO-Link					
Frequency / mode	Constant light, flashing light, blinking light					

### 3 GENERAL DESCRIPTION

Signal lighting is indispensable for safety in the industry or in the public sphere because it reliably provides a visual warning to and protects not only the workers, but also passersby. Particularly in the industry at indoor and outdoor facilities, for example, signal lighting supports workplace safety by indicating various operating states of machines and systems. Signal columns, for example, can of course be used in other situations, too. The optical signal transducers help you monitor machines and complex manufacturing processes, identify emergency or hazardous situations so that action can be taken in good time if the safety of the environment, people or products is in jeopardy. di-soric signal lights and signal lighting have the advantage that they can be configured to suit your individual needs via IO-Link. The signal lights can be integrated into any machine and system with practical accessories for signal lighting.

### 4 NORMAL OPERATION AND APPLICATION AREAS

The di-soric signal lighting and signal lights are operated with a service voltage of 18 to 30 V.

On machines and systems with IO-Link, the device is connected to a class A port of the IO-Link master with a 3 to 5-pin M12 connecting line.

On machines and systems without IO-Link, the device is connected to a 5-pin cable, with the presets being activated via the 3 digital inputs.

Even from a great distance, the signal lighting indicates the status of machines or machine segments in a clearly visible way with vibrant colors.

#### 4.1 RELIABLY SIGNALING VARIOUS STATUSES

By using professional signaling, you ensure more safety in your applications and considerably reduce response and waiting times. Due to the different signaling stages, employees can promptly react to faults and more quickly fix any existing problems. Attention is additionally drawn by the loud buzzer integrated into the cover of the SBT signal towers.

#### 4.2 SIGNAL LIGHTING: SUITABLE FOR A VARIETY OF USES

It is impossible to imagine mechanical engineering and plant construction without signal columns. But signal lighting is also found in many other areas, such as intralogistics and building services engineering.

#### 4.3 AMBIENT CONDITIONS [IP PROTECTION CLASSES]

The di-soric SBx-RGB lighting is typically suited for industrial applications; depending on the variants, they have the following IP protection types: IP20, IP 65 and IP 67.

## 5 OPERATING MODES

The di-soric LED signal lighting (SBx-RGB) can be operated via IO-Link as well as via the integrated digital inputs. In total, 4 operating modes are available: External Trigger mode, Segment mode, Level mode, Demo mode:

It is important to mention that the SBP-RGB is only operated with 3 operating modes, namely, External Trigger mode, Segment mode and Demo mode. Level mode is not possible for the SBP-RGB series because the SBP-RGB has only one segment.

### 5.1 EXTERNAL TRIGGER MODE

In **External Trigger mode** (factory setting), 8 predefined color and lighting configurations can be activated through the 3 digital trigger inputs, even without IO-Link.

### 5.2 OPERATION VIA IO-LINK [SEGMENT MODE, LEVEL MODE, DEMO MODE]

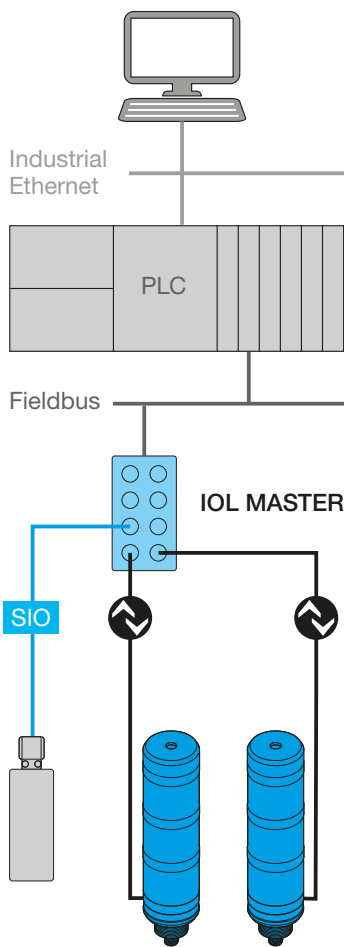

Possible system architecture

#### 5.2.1 COMMUNICATION VIA IO-LINK

IO-Link is a globally standardized I/O technology (IEC61131-9) for communication between control system and sensor/actuator below the fieldbus level.

The well-known connection technology is used with unshielded M12 cables. Here, the 3-wire connection of a digital switching signal is enhanced by the bidirectional communication.

#### 5.2.2 SEGMENT MODE

In Segment mode, individual segments can be activated via IO-Link process data, which enables countless color configurations. IO-Link can be used on the fly to set the colors of each segment, the intensity from 10 to 100% and blinking or flashing behavior.

#### 5.2.3 LEVEL MODE

Level mode is for displaying fill levels and process progress. In Level mode, the signal light requires an input value from the control system between 0 and 100 percent. Furthermore, there is the option of using IO-Link process data to define a background color (inactive segment) and a color of the active segment.

#### 5.2.4 DEMO MODE

In Demo mode, the device demonstrates the different operating functions: different colors, Level mode, Segment mode, blinking, flashing and, if present, an acoustic signal.

## 6 COMMISSIONING

For initial commissioning of our signal lighting, you need either a control system with 3 free digital outputs and a 5-wire connecting cable with M12 socket or, if you want to connect the lighting to IO-Link, then you need a compatible IO-Link master and a 5-wire connecting cable with M12 socket.

### 6.1 OPERATION WITHOUT IO-LINK IN EXTERNAL TRIGGER MODE

The lighting and/or products arrive from the factory in External Trigger mode. The 3 digital inputs can be used to activate the predefined presets for the lights. The statuses that are displayed when the respective preset is activated depend on the product and are described in the data sheet for the respective product. As an example, here is an excerpt from a data sheet from the SBP-RGB series:

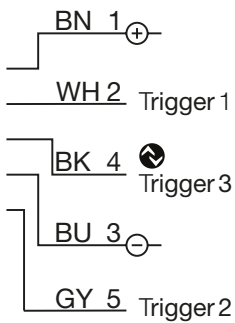

Operating mode: External Trigger				
Trig 1	Trig 2	Trig 3	Preset	Factory setting
0	0	0	1	Off
1	0	0	2	Red
0	1	0	3	Green
1	1	0	4	Yellow
0	0	1	5	Blue
1	0	1	6	Red blinking
0	1	1	7	Green blinking
1	1	1	8	Yellow blinking

All trigger inputs have a delay ~50ms. Presets can be defined via IO-Link.

### 6.2 OPERATION WITH DI-SORIC IO-LINK MASTER

Our signal lighting and signal lights from the SBx-RGB series can be configured directly with a computer running Windows 7 or later, in combination with the di-soric USB IO-LINK MASTER and the associated "IOL Device Tool" software.



IOL MASTER:  
Operation on PC via USB

The IO-Link devices are described by means of XML device descriptions, so they can be quickly and easily observed and configured. The tool is designed for presetting, testing and demonstrating IO-Link devices. The tool is not intended for ongoing operation in production systems.

In addition to the computer and IO-Link master with software, you also need the IODDs of the respective signal lights. You will find these in our product selector under the respective product on the Downloads tab.

The IODD is a ZIP file in which the actual IODD is compressed with the associated graphics files. After the files are imported into your engineering tool, the lighting functions can be visualized and programmed.

You can also find the IODDs in the IODDfinder portal of the IO-Link Consortium: [ioddfinder.io-link.com](http://ioddfinder.io-link.com)

For details about the functions and additional information for integrating IO-Link devices with the di-soric USB IO-Link master, please see the user manual for the IOL master: [www.di-soric.com/210075](http://www.di-soric.com/210075)

6.3 OPERATION WITH OTHER PLC ONLINE TOOLS: E.G. SIEMENS MASTER

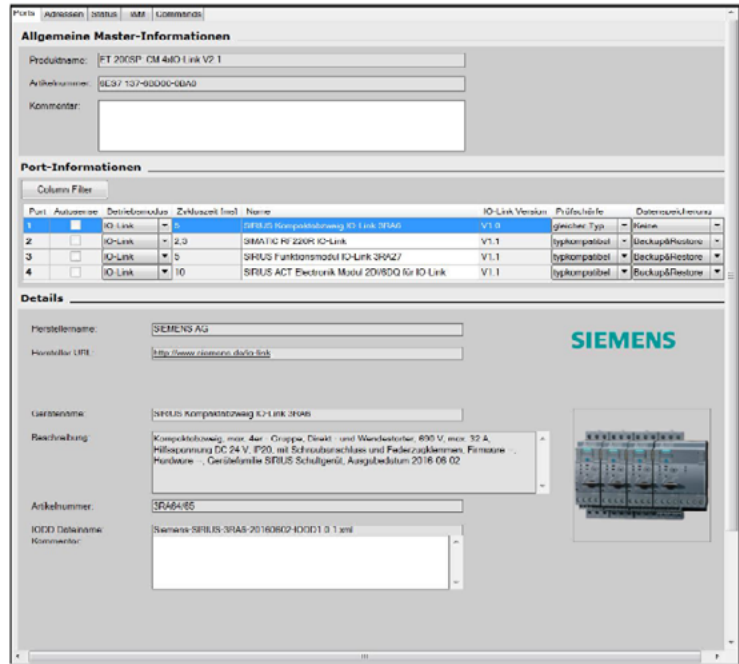

S7-PCT with IODD of a device and the contained device information

Important note: Before operation with IO-Link, the IO-Link devices should be switched from External Trigger mode (factory configuration) to Segment mode or Level mode. (see Figures 1 and 2)

It is entirely possible to use other engineering tools for planning and parameterization of IO-Link devices: Example: Siemens master with Port Configuration Tool ("PCT").

The Port Configuration Tool ("PCT") is PC-based software for parameterization of Siemens IO-Link master modules and IO-Link devices from any manufacturer. The IO-Link devices are integrated through the standardized "IODD" device description, which can be obtained from the respective device manufacturer or at the IODDfinder portal (ioddfinder.io-link.com).

With the Siemens IO-Link master, it is necessary to make sure that the latest IODD file revised for this is used. This can be identified by the time code (Release Date: 2022-04-25). For example, for the SB-RGB-126-K-B5 signal lighting it looks like this: di-soric-SB-RGB-126-K-B5-20220425-IODD1.1-de.html.

If a previous version of the IODD is installed, then this must first be completely removed from the Siemens master. Then the PCT tool must be restarted; after that, the new version can be used.

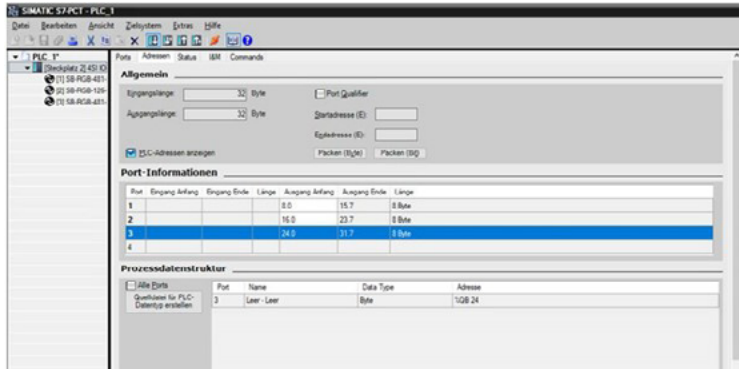

Figure 1 – External Trigger mode (factory configuration)

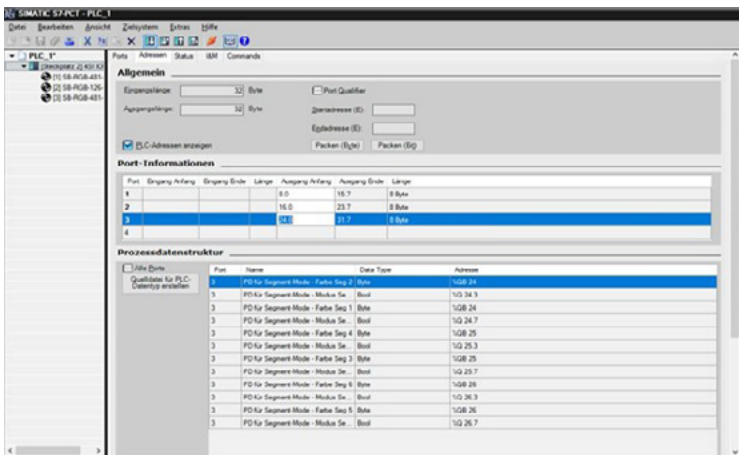

Figure 2 – Segment mode (bytes for the process data are assigned)



## 7 PARAMETERIZATION AND CONFIGURATION

### 7.1 BASIC FUNCTIONS

Among other things, di-soric signal lighting has 3 basic functions: color configuration, locator function and reset to factory settings. The colors are configured to indexes [650 to 657] by the “Color content” variable and to indexes [620 to 627] by the “Designation” variable.

The “Locator function” at index [126=Locator Start, 127=Locator Stop] and the Reset to the factory setting with the values [200 to 207] are at subindexes 16 and are located under the “Standard command” standard variable index=2 id=V\_SystemCommand.

The Locator function is at 126 for Locator Start and 127 for Locator Stop; it enables the integrated product to be quickly found in the system.

The factory settings are restored through the allowed value 130 as the subindex.

#### 7.1.1 COLOR CONFIGURATION AND DESIGNATION

In the color configuration it is possible to configure 8 different colors; the “Color content” variables lie at the indexes=650 to 657 and have the id=V\_ColorRGB0 to V\_ColorRGB7. The colors red, green and blue lie at the subindexes=1,2,3 and are indicated with values 0 to 100.

The “Designation” variables lie at the indexes=620 to 627 and have the id=V\_ColorDesignation0 to V\_Color Designation7. The color designations can be freely changed and have a data type of 32-octet string UTF-8.

##### “Color content” variable index=600 id=V\_ColorRGB0

description: Color content  
data type: 24-bit record  
access rights: rw  
dynamic

subindex	bit offset	data type	allowed values	default value	acc. restr.	mod. other var.	excl. from DS	name	description
1	16	8-bit UInteger	0 to 100	0				Red	Red part
2	8	8-bit UInteger	0 to 100	0				Green	Green part
3	0	8-bit UInteger	0 to 100	0				Blue	Blue part

octet	0	1	2
bit offset	23-16	15-8	7-0
subindex	1	2	3
element bit	7-0	7-0	7-0

Configuration color 000

##### “Designation” variable index=620 id=V\_ColorDesignation0

description: Designation can be freely selected  
data type: 32-octet string UTF-8  
default value: “Off (factory setting)”  
access rights: rw  
dynamic

octet	0	1	2	3	4	5	6	7
bit offset	255-248	247-240	239-232	231-224	223-216	215-208	207-200	199-192

octet	8	9	10	11	12	13	14	15
bit offset	191-184	183-176	175-168	167-160	159-152	151-144	143-136	135-128

octet	16	17	18	19	20	21	22	23
bit offset	127-120	119-112	111-104	103-96	95-88	87-80	79-72	71-64

octet	24	25	26	27	28	29	30	31
bit offset	63-56	55-48	47-40	39-32	31-24	23-16	15-8	7-0

Trigger preset 1 (TRIG1=0, TRIG2=0, TRIG3=0)

For example, for ColorDesignation0 the index lies at the value 620. At index=620 the color is off or dark by default (factory setting).

### 7.1.2 STANDARD COMMANDS

For the Locator function and factory setting, the “Standard command” standard variable lies at index=2 with the id=V\_SystemCommand. Restore the allowed values 126 for Locator Start and 127 for Locator Stop, as well as 130 for restoring to factory settings. For Reset to factory settings for ColorDesignation0 to 7, the allowed values lie between [200 to 207].

**“Standard command” standard variable index=2 id=V\_SystemCommand**

data type: 32-octet string UTF-8

allowed value: 126=Locator start, 127=Locator Stop, 130=Restore factory settings, 161=Function test, 162= Function test stop, 200=Reset to factory settings, 201=Reset to factory settings, 202=Reset to factory settings, 203=Reset to factory settings, 204=Reset to factory settings, 205=Reset to factory settings, 206=Reset to factory settings, 207=Reset to factory settings, 240=IO-Link 1.1 system test command 240, Event 8DFF appears, 243=IO-Link 1.1 system test command 243, Event 8DFF appears

access rights: wo

modifies other variables

octet	0	
bit offset	7-0	
element bit	7-0	

The Locator function enables the integrated product to be quickly found in the system. The factory settings are restored through the allowed value 130 as the subindex.

## 8 OPERATING MODES

The signal lighting of the SB- and SBT-RGB series have four operating modes, which can be set by means of the “device control” parameter:

- External Trigger mode (factory configuration)
- Segment mode (PD)
- Level mode (PD) [not available for the SBP lighting series]
- Demo mode

The operating modes can only be selected individually and cannot be combined. The operating mode is set by means of the “device control” parameter.

**“Device control” variable index=602 id=V\_DeviceControl**

description: Device control

data type: 8-bit UInteger

allowed value: 1=External Trigger mode, 2=Segment mode (PD), 3=Level mode (PD), 4=Demo mode

default value: 1

access rights: rw

octet	0	
bit offset	7-0	
element bit	7-0	

The device control has index=602, the allowed values are 1=External Trigger mode, 2=Segment mode (PD), 3=Level mode (PD), and 4=Demo mode. The default value or standard value is typically 1 (external trigger).

## 8.1 EXTERNAL TRIGGER MODE [STANDARD MODE]

The signal lighting of the SB-, SBP- and SBT-RGB series is delivered in Trigger mode. (factory configuration). This is the standard operating mode at delivery. In this operating mode, each color of each segment is represented as a separate switching signal.

Important note: Complete integration into IO-Link is possible only with the new Gen. 2 devices possible, and these are stipulated in this manual.

The delivery of Generation 2 lighting in Trigger mode enables backward compatibility with the devices of Generation 1. Furthermore, Generation 1 devices differ from Generation 2 devices in terms of voltage range (Gen. 1: 24 V DC +-5%, Gen. 2: 18 to 30 V DC).

### Preset color for each segment simulation

#### “Preset selection” variable index=604 id=V\_TriggerSimulation

description: Simulation of all eight selectable presets in External Trigger mode in parallel with an IO-Link connection

data type: 8-bit UInteger

allowed value: 0=0 (simulation off), 1=preset 1, 2=preset 2, 3=preset 3, 4=preset 4, 5=preset 5, 6=preset 6, 7=preset 7, 8=preset 8

default value: 0

access rights: rw

excluded from data storage

octet	0
bit offset	7-0
element bit	7-0

For simulation of all eight selectable presets in Trigger mode, the index has the value 604 and the allowed base values for the presets are [ 0- 8 ]: 0=(simulation off), 1=preset 1, 2=preset 2, 3=preset 3, 4=preset 4, 5=preset 5, 6=preset 6, 7=preset 7, 8=preset 8.

The default value or base value is typically 0.

### 8.1.1 PARAMETERIZATION [PARAMETER DATA]

Trigger mode means that customers can use digital inputs to switch predefined colors directly. Due to the 3 trigger inputs of the lighting, the 8 predefined trigger presets can be selected.

For a trigger preset selection [preset 0 to 7], the following light functions (light color, intensity and mode) and buzzer function are preset at the factory for each segment [1 to 12] (depending on the variant). However, there is the option of simply using IO-Link to freely and individually parameterize the trigger presets.

Recommended procedure for commissioning:

1. Configure colors
2. Configure presets
3. Simulate presets

## Buzzer function

For the variants that have a buzzer, a buzzer can also be configured in addition to the color configurations. Here, you can decide whether the buzzer should emit a continuous tone or a slow or fast intermittent tone.

### “Buzzer” variable index=700 id=V\_SegmentPre-Set1\_Buzzer

description: slow intermittent (1 Hz) / fast intermittent (2.5 Hz)

data type: 8-bit UInteger

allowed value: 0=off, 1=on (continuous), 2=slow intermittent, 3=fast intermittent

default value: 0

access rights: rw

octet	0
bit offset	7-0
element bit	7-0

## Preset for each segment

In the preset segment configuration, the previously configured colors can be assigned to the individual presets or segments. In addition, you can configure the light intensity as well as have the active segment be lit continuously, blink or flash.

### “Seg 1” variable index=701 id=V\_SegmentPre-Set1\_1

description: Segment preset

data type: 24-bit record

access rights: rw

subindex	bit offset	data type	allowed values	default value	acc. restr.	mod. other var.	excl. from DS	name	description
1	16	8-bit UInteger	0=color 001, 2=color 010, 3=color 011, 4=color 100, 5=color 101, 6=color 110, 7=color 111	0				Color	Color
2	8	8-bit UInteger	0 to 100	100				Intensity	Intensity
3	0	8-bit UInteger	0=static, 1=blinking, 2=flashing	0				Color	Mode

octet	0	1	2
bit offset	23-16	15-8	7-0
subindex	1	2	3
element bit	7-0	7-0	7-0

## 8.1.2 APPLICATION EXAMPLE

To activate the color red in Trigger mode, the following pin assignment is connected:

Pin 2 (TRIG 1)=VDD, High level > 8.0 V

Pin 5 (TRIG 2)=GND, Low level < 5.0 V

Pin 4 (TRIG 3)=GND, Low level < 5.0 V

For the color green, the following pin assignment is required:

Pin 2 (TRIG 1)=GND, Low level < 5.0 V

Pin 5 (TRIG 2)=VDD, High level > 8.0 V

Pin 4 (TRIG 3)=GND, Low level < 5.0 V

## 8.2 SEGMENT MODE

If the signal lighting or signal lights are completely integrated into the IO-Link communication, then it is advisable to operate the product in Segment mode.

In Segment mode, individual segments can be activated via IO-Link process data, which enables countless color configurations. IO-Link can be used on the fly to assign the previously configured colors and static, blinking or flashing lighting behavior to the segments.

### 8.2.1 PARAMETERIZATION [PARAMETER DATA]

Depending on the selected number of segments, the various color combinations can be displayed. The intensity [10 to 100] and Dynamic mode [blinking or flashing] can also be set up freely.

The “Number of segments selection 1=1” setting applies the selected color to all the lighting. Important note: The index 610 is not available for the SBP-RGB lighting.

#### Number of segments selection

##### “Number of segments selection” variable index=610 id=V\_SelectionSegmentNumber

description: Selection of the number of segments in Segment mode (PD)  
 data type: 8-bit Ulnteger  
 allowed value: 1=1, 5=5  
 default value: 5  
 access rights: rw

#### Dynamic mode for each segment

In Segment mode, for example, for segment 1 the result is index=681 and for the intensity the result is subindex=1 and the values are [10 to 100]. The factory setting is usually 100.

For Dynamic mode, the subindex=2 and the possible values are 1=blinking and 2=flashing. For the factory setting, the value=1 is usually set.

##### “Seg 1” variable index=681 id=V\_SegmentModus1

description: Segment  
 data type: 16-bit record  
 access rights: rw

subindex	bit offset	data type	allowed values	default value	acc. restr.	mod. other var.	excl. from DS	name	description
1	8	8-bit Ulnteger	10 to 100	100				Intensity	Intensity
2	0	8-bit Ulnteger	1=blinking, 2=flashing	1				Dynamic mode	Dynamic mode

octet	0	1
bit offset	15-8	7-0
subindex	1	2
element bit	7-0	7-0

### 8.2.2 PROCESS DATA AND APPLICATION EXAMPLE

The process data of the devices is transmitted cyclically in a data telegram; the device defines the process data size. For each device it is possible to have process data from 0 to 32 bytes (for both the input and output). In Segment mode, the process data can be used to assign the 8 preconfigured colors to the individual segments or activate them. Furthermore, the (static or dynamic) lighting mode can be selected for each segment. In addition, if products have a buzzer, this can be activated.

The ProcessDataOut "PD for Segment mode" is under the id=PDOOUT\_Segment at V\_DeviceControl == 2. For example, the color setting for Seg 3 is at subindex 6 and the buzzer is at subindex 7.

**ProcessData id=PD\_Segment (condition V\_DeviceControl ==2)**

**ProcessDataOut "PD for Segment mode" id=PDOOUT\_Segment**

bit length: 64

data type: 64-bit record (subindex access not supported)

subindex	bit offset	data type	allowed values	default value	acc. restr.	mod. other var.	excl. from DS	name	description
1	63	Boolean	false=static, true=dynamic					Seg 1 mode	
2	60	3-bit UInteger	0=color 000, 1=color 001, 2=color 010, 3=color 011, 4=color 100, 5=color 101, 6=color 110, 7=color 111					Seg 1 color	
3	59	Boolean	false=static, true=dynamic					Seg 2 mode	
4	56	3-bit UInteger	0=color 000, 1=color 001, 2=color 010, 3=color 011, 4=color 100, 5=color 101, 6=color 110, 7=color 111					Seg 2 color	
5	55	Boolean	false=static, true=dynamic					Seg 3 mode	
6	52	3-bit UInteger	0=color 000, 1=color 001, 2=color 010, 3=color 011, 4=color 100, 5=color 101, 6=color 110, 7=color 111					Seg 3 color	
7	51	Boolean	false=static, true=dynamic					Seg 4 mode	
8	48	3-bit UInteger	0=color 000, 1=color 001, 2=color 010, 3=color 011, 4=color 100, 5=color 101, 6=color 110, 7=color 111					Seg 4 color	
9	47	Boolean	false=static, true=dynamic					Seg 5 mode	
10	44	3-bit UInteger	0=color 000, 1=color 001, 2=color 010, 3=color 011, 4=color 100, 5=color 101, 6=color 110, 7=color 111					Seg 5 color	
11	0	2-bit UInteger	0=off, 1=on (continuous), 2=slow intermittent, 3=fast intermittent					Buzzer	

In Segment mode, the number of segments [1 to 12] of lighting (depending on variant) can be easily displayed and the preconfigured colors [000 to 111] selected for each segment can be optically visualized.

A variety of information can be clearly and optically displayed with the segments. The Segment mode setting causes the lighting to accept only the commands for color changes, activation via the I/O-Link connection.

In Segment mode, the signal lighting can be used to display process progress. Thus the machine operator can immediately determine the current status of manufacturing processes and act accordingly in case of error messages.

## 8.3 LEVEL MODE

In Level mode, it is possible to use IO-Link process data to define a background color [inactive segment], which can be used, for example, as a corporate identity color. In addition, the fill levels and machine status can be displayed with the active segments [foreground color] with a predefined color selection.

### 8.3.1 PARAMETERIZATION [PARAMETER DATA]

Important note: Level mode is not available for SBP-RGB lighting because it has only one segment.

#### Segment behavior

##### “Mode” variable index=616 id=V\_LevelMode

description: Mode  
 data type: 8-bit UInteger  
 allowed value: 0=segments increasing, 1=segment migrating  
 default value: 0  
 access rights: rw

octet	0	
bit offset	7-0	
element bit	7-0	

For example, for Level mode the index=616 and the allowed values are 0=segments increasing, 1=segment migrating.

#### Level display direction

With the signal lighting Level mode, the display direction [Bottom>Top or Top>Bottom] can also be selected and optically displayed.

##### “Display direction” variable index=615 id=V\_LevelDisplayDirection

description: Display direction  
 data type: 8-bit UInteger  
 allowed value: 0=Bottom > Top, 1=Top > Bottom  
 default value: 0  
 access rights: rw

octet	0	
bit offset	7-0	
element bit	7-0	

#### Dynamic mode for each segment

Furthermore, it is possible to define a foreground color with the index=617 [active segment level] and a background color with the index 618 [inactive segment level]. For example, the background color can be set as a corporate identity color.

##### “Active segment dynamic mode” variable index=617 id=V\_LevelActiveSegment

description: Active segment dynamic mode (foreground color)  
 data type: 8-bit UInteger  
 allowed value: 1=blinking, 2=flashing  
 default value: 1  
 access rights: rw

octet	0	
bit offset	7-0	
element bit	7-0	

**“Inactive segment dynamic mode” variable index=618 id=V\_LevelInactiveSegment**

description: Inactive segment dynamic mode (background color)

data type: 8-bit Ulnteger

allowed value: 1=blinking, 2=flashing

default value: 1

access rights: rw

octet	0
bit offset	7-0
element bit	7-0

**8.3.2 PROCESS DATA AND APPLICATION EXAMPLE**

Process data (e.g. analog values) are transmitted cyclically. In Level mode, the process data transmits the analog value [0 to 100] as an input, for example, so that fill levels and process progress can be displayed. The 8 preconfigured colors can be freely set for the active segments as well as for the inactive segments. Furthermore, the (static or dynamic) lighting mode can be selected. In addition, the buzzer can be activated. The buzzer's tone mode [slow or fast intermittent] can also be freely selected.

**ProcessData id=PD\_Level (condition V\_DeviceControl ==3)****ProcessDataOut “PD for Level mode” id=PDOOUT\_Level**

bit length: 64

data type: 64-bit record (subindex access not supported)

subindex	bit offset	data type	allowed values	default value	acc. restr.	mod. other var.	excl. from DS	name	description
1	56	8-bit Ulnteger	0 to 100					Analog value	
2	51	Boolean	false=static, true=dynamic					Active segments mode	
3	48	3-bit Ulnteger	0=color 000, 1=color 001, 2=color 010, 3=color 011, 4=color 100, 5=color 101, 6=color 110, 7=color 111					Active segments color	
4	40	7-bit Ulnteger	10 to 100					Active segments intensity	
5	35	Boolean	false=static, true=dynamic					Inactive segments mode	
6	32	3-bit Ulnteger	0=color 000, 1=color 001, 2=color 010, 3=color 011, 4=color 100, 5=color 101, 6=color 110, 7=color 111					Inactive segments color	
7	24	7-bit Ulnteger	10 to 100					Inactive segments intensity	
8	0	2-bit Ulnteger	0=off, 1=on (continuous), 2=slow intermittent, 3=fast intermittent					Buzzer	

The ProcessDataOut “PD for Level mode” is under the id=PDOOUT\_Level at V\_DeviceControl == 3. As an example, the “intensity of active segments” is at subindex 4 with the allowed values [10 to 100].

The fill levels and/or machine status are displayed with the active segments [foreground color] with preconfigured color selection for the respective process. In accordance with the color selection predefined by the user, fill levels in the process can be displayed more efficiently with lit LED segments. The allocation of the analog value depends on the available number of segments.



## 9 TROUBLESHOOTING

### 9.1 ERROR DISPLAY

Error types for the signal lighting of the SBx-RGB series

Code	Additional code	Name	Description
128 (0x80)	0 (0x00)	Application error in device – no details	Access was denied by device. No detailed information available
128 (0x80)	17 (0x11)	Index not available	Access to a nonexistent index
128 (0x80)	18 (0x12)	Subindex not available	Access to a nonexistent subindex
128 (0x80)	32 (0x20)	Service currently unavailable	Currently the parameter cannot be accessed. The device does not allow this in the current status.
128 (0x80)	35 (0x23)	Access denied	Write access to a write-protected parameter
128 (0x80)	48 (0x30)	Parameter value outside the valid range	Written parameter value lies outside the allowed value range.
128 (0x80)	49 (0x31)	Parameter value above the allowed limit	Written parameter value lies above the allowed value range.
128 (0x80)	50 (0x32)	Parameter value below the allowed limit	Written parameter value lies below the allowed value range.
128 (0x80)	51 (0x33)	Parameter length too large	Written parameter value is larger than allowed.
128 (0x80)	52 (0x34)	Parameter length too small	Written parameter value is smaller than allowed.
128 (0x80)	53 (0x35)	Function not available	Written command is not supported by the device.
128 (0x80)	54 (0x36)	Function currently unavailable	Written command is not supported by the device in the current status.
128 (0x80)	64 (0x40)	Invalid parameter set	Written individual parameter value collides with the other parameter settings.
128 (0x80)	65 (0x41)	Inconsistent parameter set	Inconsistencies were detected at the end of the block parameter transfer. The device plausibility check failed.
128 (0x80)	130 (0x82)	Application not ready	Access was denied because the device is not ready currently.

**SOLUTIONS. CLEVER. PRACTICAL.**

© di-soric | All information is subject to change. Contents may contain mistakes or print errors and are subject to technical changes. | 600017-0000EN: Rev 1 - 202301

di-soric GmbH & Co. KG | Steinbeisstrasse 6 | 73660 Urbach | Germany  
Phone +49 71 81 98 79-0 | Fax +49 71 81 98 79-179 | info@di-soric.com

[www.di-soric.com](http://www.di-soric.com)