

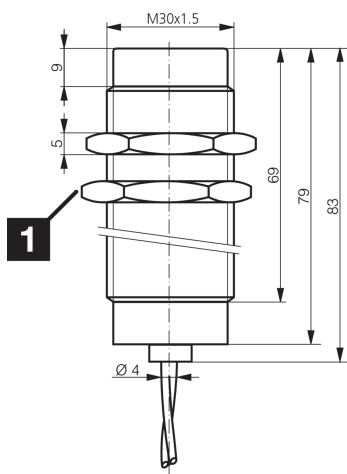

203356
DCC 30 VH 15 PSK/180
Inductive proximity sensor

- High-temperature resistant up to 180 °C permanent temperature
- Stainless steel housing
- Sensing surface LCP
- Cable material PTFE
- Integrated amplifier
- Short-circuit protection
- Starting pulse suppression



1) Width over flats 36 mm

BK: black

BN: brown

BU: blue

Function



Technical data (typ.)

+20°C, 24 V DC

Service voltage	10 ... 30 V DC
Internal power consumption	10 mA
Insulation voltage endurance	500 V
Installation type	non-flush
Thread	M30 x 1.5
Housing length	79 mm
Housing material	Stainless steel (LCP)
Material of cable	PTFE
Tightening torque (max.)	150 Nm
Protection class	III, operation on protective low voltage
Operating principle	inductive
Evaluation	digital
Design	Thread
Characteristics	< +180 °C, high-temperature resistant
Product series	INH High-temperature resistant
Switching output	pnp, 150 mA, NO
Voltage drop (max.)	2 V
Switching distance (SN)	15 mm
Standardized measuring plate	45 x 45 x 1 mm
Switching hysteresis (max.)	3 ... 15 %



203356

DCC 30 VH 15 PSK/180

Inductive proximity sensor

Technical data (typ.)

+20°C, 24 V DC

Switching frequency

200 Hz

Ambient temperature during operation

0 ... +180 °C (Sensor)

Protection type

IP 65

Connection

Cable, 2.0 m (flying leads)

More information / accessories

<https://www.di-soric.com/203356>