

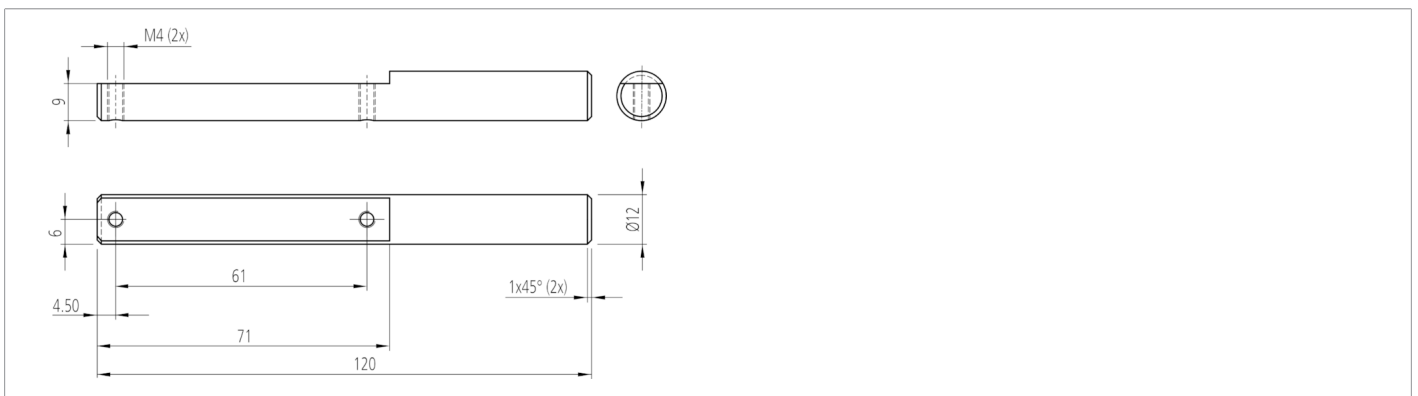

208257
HS-PH-12-120-A
Product holder

- Highly flexible versatile mounting system
- Universal mounting
- Stepless adjustment
- Robust design

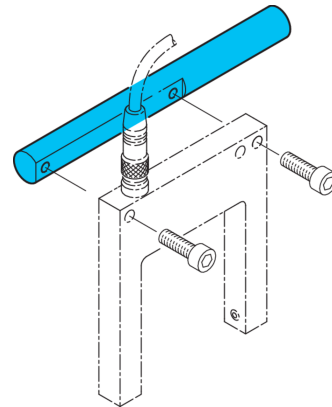

Technical data (typ.)

Dimension

+20°C

Ø 12 mm (Diameter Mounting pin / boring)

Housing material

Aluminum

Component

Product holder

To be used for

OGUxx 05x fork light barriers...

Product series

Z-UBT-KL-PH Product bracket

More information / accessories

<https://www.di-soric.com/208257>