

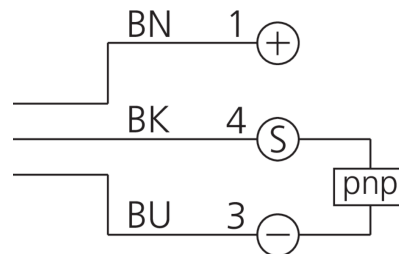

210482
DCC 05 V 1.5 PSK-TSL
Inductive proximity sensor

- Stainless steel housing
- Metal connector M8
- Integrated amplifier
- Short-circuit protection
- Starting pulse suppression
- LED

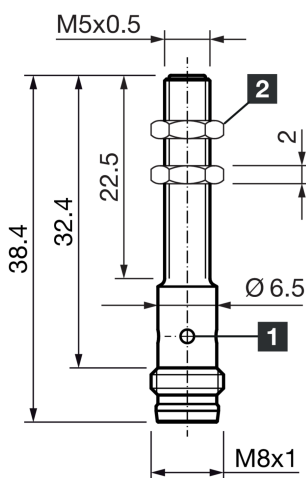

1) LED 4 x 90° (yellow)

2) Width over flats 7 mm

BK: black

BN: brown

BU: blue

Function



Technical data (typ.)

+20°C, 24 V DC

Service voltage	10 ... 30 V DC
Internal power consumption	< 10 mA
Insulation voltage endurance	500 V
Installation type	Flush
Thread	M5 x 0.5
Housing length	38.4 mm
Housing material	Stainless steel (AISI303)
Material of sensor probe	PBT
Protection class	III, operation on protective low voltage
Operating principle	inductive
Evaluation	digital
Design	Thread
Characteristics	increased operating distance
Product series	INM-300 Miniature Extended
Switching output	pnp, 100 mA, NO
Voltage drop (max.)	1.5 V (100 mA)
Switching distance (SN)	1.5 mm
Standardized measuring plate	4 x 4 x 1 mm
Switching hysteresis (max.)	1 ... 20 %
LED Anzeige	Yes



210482

DCC 05 V 1.5 PSK-TSL

Inductive proximity sensor

Technical data (typ.)

+20°C, 24 V DC

Switching frequency

5000 Hz

Ambient temperature during operation

-25 ... +70 °C

Protection type

IP 67

Connection

Connector, M8, 3-pin, A-coded

Connection cable

TK ...

More information / accessories

<https://www.di-soric.com/210482>