

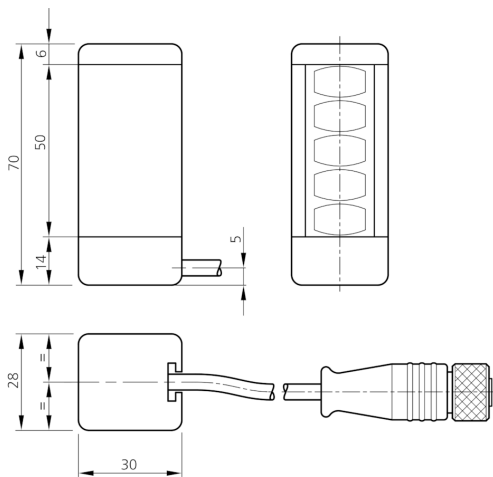

**212739**  
**M5-B**

- Muting sensor for palletizers
- Detection of irregular loads and pallets
- 5 beams
- Beam coding

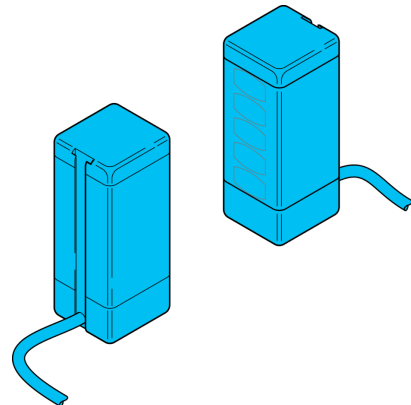

SENDER / TRANSMITTER		PIN	SIGNAL	OPERATION
		1	24VDC	24 V DC power supply
		2	DISABLE	Aktivierung Enable (0 V DC aktive / 24 V DC inactive)
		3	0VDC	
		4	-	
		5	PE	

EMPFÄNGER / RECEIVER		PIN	SIGNAL	OPERATION
		1	24VDC	24 V DC power supply
		2	-	
		3	0VDC	
		4	OUT	24 V DC Objekt erkannt / Object detected
		5	PE	

### Function



### Technical data (typ.)

Service voltage	19.2 ... 28.8 V DC
Housing dimensions	70 x 28 x 30 mm
Characteristic variables	Typ 4
Model	Through-beam sensor
Operating principle	Through-beam sensor
Evaluation	digital
Characteristics	Beam coding B
Consisting of	Transmitter and Receiver
Switching output	pnp, 100 mA
Beam separation	10 mm
Number of beams	5
Display	LED Green - Status
Reaction time	100 ms
Ambient temperature during operation	-30 ... +55 °C
Protection type	IP 65
Connection	Cable/socket, 0.9 m, M12, 5-pin

### More information / accessories

<https://www.di-soric.com/212739>